

OPERATION MANUAL



***WHITEMAN* SERIES**

MODEL HHXD5

RIDE-ON TROWEL

(B & S VANGUARD DM 950 DT DIESEL ENGINE)

Revision #2 (05/04/12)

To find the latest revision of this
publication, visit our website at:
www.multiquip.com



THIS MANUAL MUST ACCOMPANY THE EQUIPMENT AT ALL TIMES.

PN: 23323



CALIFORNIA — Proposition 65 Warning

Engine exhaust and some of its constituents, and some dust created by power sanding, sawing, grinding, drilling and other construction activities contains chemicals known to the State of California to cause cancer, birth defects and other reproductive harm. Some examples of these chemicals are:

- Lead from lead-based paints.
- Crystalline silica from bricks.
- Cement and other masonry products.
- Arsenic and chromium from chemically treated lumber.

Your risk from these exposures varies, depending on how often you do this type of work. To reduce your exposure to these chemicals: ALWAYS work in a well ventilated area, and work with approved safety equipment, such as dust masks that are specially designed to filter out microscopic particles.

SILICOSIS/RESPIRATORY WARNINGS

⚠️ WARNING



SILICOSIS WARNING

Grinding/cutting/drilling of masonry, concrete, metal and other materials with silica in their composition may give off dust or mists containing crystalline silica. Silica is a basic component of sand, quartz, brick clay, granite and numerous other minerals and rocks. Repeated and/or substantial inhalation of airborne crystalline silica can cause serious or fatal respiratory diseases, including silicosis. In addition, California and some other authorities have listed respirable crystalline silica as a substance known to cause cancer. When cutting such materials, always follow the respiratory precautions mentioned above.

⚠️ WARNING

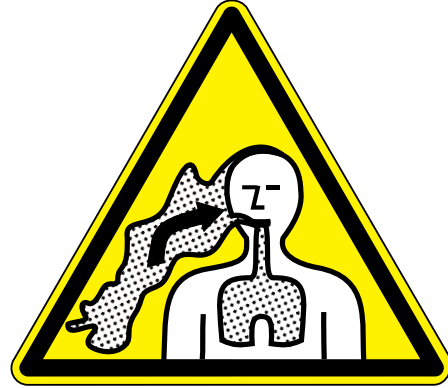

RESPIRATORY HAZARDS

Grinding/cutting/drilling of masonry, concrete, metal and other materials can generate dust, mists and fumes containing chemicals known to cause serious or fatal injury or illness, such as respiratory disease, cancer, birth defects or other reproductive harm. If you are unfamiliar with the risks associated with the particular process and/or material being cut or the composition of the tool being used, review the material safety data sheet and/or consult your employer, the material manufacturer/supplier, governmental agencies such as OSHA and NIOSH and other sources on hazardous materials. California and some other authorities, for instance, have published lists of substances known to cause cancer, reproductive toxicity, or other harmful effects.

Control dust, mist and fumes at the source where possible. In this regard use good work practices and follow the recommendations of the manufacturers or suppliers, OSHA/NIOSH, and occupational and trade associations. Water should be used for dust suppression when wet cutting is feasible. When the hazards from inhalation of dust, mists and fumes cannot be eliminated, the operator and any bystanders should always wear a respirator approved by NIOSH/MSHA for the materials being used.

TABLE OF CONTENTS

HHXD5 Ride-On Trowel

Proposition 65 Warning	2
Silicosis/Respiratory Warnings	3
Table Of Contents	4
Training Checklist	6
Daily Pre-Operation Checklist	7
Safety Information	8-13
Dimensions/Specifications.....	14-15
General Information.....	16
Controls And Indicators	17-19
Engine Components (Diesel).....	20
Setup	21
Inspection	22
Operation.....	23-25
Maintenance	26-44
Decommissioning Trowel	45
Fuel System Diagram	46
Wiring Diagram (Engine)	48-49
Troubleshooting	50-53

NOTICE

Specifications and part numbers are subject to change without notice.

TRAINING CHECKLIST

TRAINING CHECKLIST

This checklist will list some of the minimum requirements for machine maintenance and operation. Please feel free to detach it and make copies. Use this checklist whenever a new operator is to be trained or it can be used as a review for more experienced operators.

Training Checklist			
No,	Description	OK?	Date
1	Read operation manual completely.		
2	Machine layout, location of components, checking of engine and hydraulic oil levels.		
3	Fuel system, refueling procedure.		
4	Operation of spray and lights.		
5	Operation of controls (machine not running).		
6	Safety controls, safety stop switch operation.		
7	Emergency stop procedures.		
8	Startup of machine, pre-heat, engine choke.		
9	Maintaining a hover.		
10	Maneuvering.		
11	Pitching.		
12	Matching blade pitch. Twin-Pitch™		
13	Concrete finishing techniques.		
14	Shutdown of machine.		
15	Lifting of machine (lift loops).		
16	Machine transport and storage.		

DAILY PRE-OPERATION CHECKLIST

Daily Pre-Operation Checklist		✓	✓	✓	✓	✓	✓
1	Engine oil level						
2	Hydraulic oil level						
3	Radiator coolant level						
4	Condition of blades						
5	Blade pitch operation						
6	Safety stop switch operation						
7	Steering control operation						

SAFETY INFORMATION

Do not operate or service the equipment before reading the entire manual. Safety precautions should be followed at all times when operating this equipment. Failure to read and understand the safety messages and operating instructions could result in injury to yourself and others.



SAFETY MESSAGES

The four safety messages shown below will inform you about potential hazards that could injure you or others. The safety messages specifically address the level of exposure to the operator and are preceded by one of four words: **DANGER**, **WARNING**, **CAUTION** or **NOTICE**.

SAFETY SYMBOLS

! DANGER

Indicates a hazardous situation which, if not avoided, **WILL** result in **DEATH** or **SERIOUS INJURY**.

! WARNING

Indicates a hazardous situation which, if not avoided, **COULD** result in **DEATH** or **SERIOUS INJURY**.

! CAUTION

Indicates a hazardous situation which, if not avoided, **COULD** result in **MINOR** or **MODERATE INJURY**.

NOTICE

Addresses practices not related to personal injury.

Potential hazards associated with the operation of this equipment will be referenced with hazard symbols which may appear throughout this manual in conjunction with safety messages.

Symbol	Safety Hazard
	Lethal exhaust gas hazards
	Explosive fuel hazards
	Burn hazards
	Rotating parts hazards
	Pressurized fluid hazards
	Hydraulic fluid hazards

SAFETY INFORMATION

GENERAL SAFETY

CAUTION

- **NEVER** operate this equipment without proper protective clothing, shatterproof glasses, respiratory protection, hearing protection, steel-toed boots and other protective devices required by the job or city and state regulations.



- Avoid wearing jewelry or loose fitting clothes that may snag on the controls or moving parts as this can cause serious injury.

- **NEVER** operate this equipment when not feeling well due to fatigue, illness or when under medication.



- **NEVER** operate this equipment under the influence of drugs or alcohol.



- **ALWAYS** clear the work area of any debris, tools, etc. that would constitute a hazard while the equipment is in operation.

- No one other than the operator is to be in the working area when the equipment is in operation.

- **DO NOT** use the equipment for any purpose other than its intended purposes or applications.

NOTICE

- This equipment should only be operated by trained and qualified personnel 18 years of age and older.

- Whenever necessary, replace nameplate, operation and safety decals when they become difficult read.

- Manufacturer does not assume responsibility for any accident due to equipment modifications. Unauthorized equipment modification will void all warranties.

- **NEVER** use accessories or attachments that are not recommended by Multiquip for this equipment. Damage to the equipment and/or injury to user may result.

- **ALWAYS** know the location of the nearest fire extinguisher.



- **ALWAYS** know the location of the nearest first aid kit.



- **ALWAYS** know the location of the nearest phone or **keep a phone on the job site**. Also, know the phone numbers of the nearest **ambulance, doctor** and **fire department**. This information will be invaluable in the case of an emergency.



SAFETY INFORMATION

TROWEL SAFETY

DANGER

- Engine fuel exhaust gases contain poisonous carbon monoxide. This gas is colorless and odorless, and can cause death if inhaled.
- The engine of this equipment requires an adequate free flow of cooling air. **NEVER** operate this equipment in any enclosed or narrow area where free flow of the air is restricted. If the air flow is restricted it will cause injury to people and property and serious damage to the equipment or engine.



- **NEVER** operate the equipment in an explosive atmosphere or near combustible materials. An explosion or fire could result causing severe **bodily harm or even death.**



WARNING

- If applicable, **NEVER** use your hand to find hydraulic leaks. Use a piece of wood or cardboard. Hydraulic fluid injected into the skin must be treated by a knowledgeable physician immediately or severe injury or death can occur.
- **ALWAYS** keep clear of rotating or moving parts while operating the trowel.
- **NEVER** disconnect any **emergency or safety devices.** These devices are intended for operator safety. Disconnection of these devices can cause severe injury, bodily harm or even death. Disconnection of any of these devices will void all warranties.



CAUTION

- **NEVER** allow passengers or riders on the trowel during operation.
- **NEVER** lubricate components or attempt service on a running machine.
- **NEVER** place your feet or hands inside the guard rings while starting or operating this equipment.

NOTICE

- **ALWAYS** keep the machine in proper running condition.
- Fix damage to machine and replace any broken parts immediately.
- **ALWAYS** store equipment properly when it is not being used. Equipment should be stored in a clean, dry location out of the reach of children and unauthorized personnel.
- A safety manual for operating and maintenance personnel of concrete power trowels produced by the Association of Equipment Manufacturers (AEM) can be obtained for a fee by ordering through their website at www.aem.org.

Order FORM PT-160

ENGINE SAFETY

WARNING

- **DO NOT** place hands or fingers inside engine compartment when engine is running.
- **NEVER** operate the engine with heat shields or guards removed.
- Keep fingers, hands hair and clothing away from all moving parts to prevent injury.
- **DO NOT** remove the radiator cap while the engine is hot. High pressure boiling water will gush out of the radiator and severely scald any persons in the general area of the trowel.
- **DO NOT** remove the coolant drain plug while the engine is hot. Hot coolant will gush out of the coolant tank and severely scald any persons in the general area of the trowel.
- **DO NOT** remove the engine oil drain plug while the engine is hot. Hot oil will gush out of the oil tank and severely scald any persons in the general area of the trowel.



CAUTION

- **NEVER** touch the hot exhaust manifold, muffler or cylinder. Allow these parts to cool before servicing equipment.



SAFETY INFORMATION

NOTICE

- **NEVER** run engine without an air filter or with a dirty air filter. Severe engine damage may occur. Service air filter frequently to prevent engine malfunction.
- **NEVER** tamper with the factory settings of the engine or engine governor. Damage to the engine or equipment can result if operating in speed ranges above the maximum allowable.



FUEL SAFETY

DANGER

- **DO NOT** start the engine near spilled fuel or combustible fluids. Fuel is extremely flammable and its vapors can cause an explosion if ignited.
- **ALWAYS** refuel in a well-ventilated area, away from sparks and open flames.
- **ALWAYS** use extreme caution when working with **flammable** liquids.
- **DO NOT** fill the fuel tank while the engine is running or hot.
- **DO NOT** overfill tank, since spilled fuel could ignite if it comes into contact with hot engine parts or sparks from the ignition system.
- Store fuel in appropriate containers, in well-ventilated areas and away from sparks and flames.
- **NEVER** use fuel as a cleaning agent.
- **DO NOT** smoke around or near the equipment. Fire or explosion could result from fuel vapors or if fuel is spilled on a hot engine.



BATTERY SAFETY

DANGER

- **DO NOT** drop the battery. There is a possibility that the battery will explode.
- **DO NOT** expose the battery to open flames, sparks, cigarettes, etc. The battery contains combustible gases and liquids. If these gases and liquids come into contact with a flame or spark, an explosion could occur.

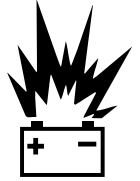

WARNING

- **ALWAYS** wear safety glasses when handling the battery to avoid eye irritation. The battery contains acids that can cause injury to the eyes and skin.
- Use well-insulated gloves when picking up the battery.
- **ALWAYS** keep the battery charged. If the battery is not charged, combustible gas will build up.
- **DO NOT** charge battery if frozen. Battery can explode. When frozen, warm the battery to at least 61°F (16°C).
- **ALWAYS** recharge the battery in a well-ventilated environment to avoid the risk of a dangerous concentration of combustible gases.
- If the battery liquid (dilute sulfuric acid) comes into contact with **clothing or skin**, rinse skin or clothing immediately with plenty of water.
- If the battery liquid (dilute sulfuric acid) comes into contact with **eyes**, rinse eyes immediately with plenty of water and contact the nearest doctor or hospital to seek medical attention.



CAUTION

- **ALWAYS** disconnect the **NEGATIVE** battery terminal before performing service on the equipment.
- **ALWAYS** keep battery cables in good working condition. Repair or replace all worn cables.

SAFETY INFORMATION

TRANSPORTING SAFETY

⚠ CAUTION

- **NEVER** allow any person or animal to stand underneath the equipment while lifting.
- Ride-on trowels are very heavy and awkward to move around. Use proper heavy lifting procedures and **DO NOT** attempt to lift the trowel by the guard rings.



NOTICE

- The easiest way to lift the trowel is to utilize the lift loops that are welded to the frame. These lift loops are located to the left and right sides of the operator's seat.

A strap or chain can be attached to these lift loops, allowing a forklift or crane to lift the trowel up onto and off of a slab of concrete. The strap or chain should have a minimum of 2,000 pounds (1,000 kg) lifting capacity and the lifting gear must be capable of lifting at least this amount.

- **NEVER** transport trowel with float pans attached unless safety catches are used and are specifically cleared for such transport by the manufacturer.
- **NEVER** hoist the trowel more than three feet off the ground with float pans attached.
- Before lifting, make sure that the lift loops are not damaged.
- Always make sure crane or lifting device has been properly secured to the lift loops of the equipment.
- **ALWAYS** shutdown engine before transporting.
- **NEVER** lift the equipment while the engine is running.
- Tighten fuel tank cap securely and close fuel cock to prevent fuel from spilling.
- Use adequate lifting cable (wire or rope) of sufficient strength.
- **DO NOT** lift machine to unnecessary heights.
- **ALWAYS** tie down equipment during transport by securing the equipment with rope.

TOWING SAFETY

⚠ CAUTION

- Check with your local county or state safety towing regulations, in addition to meeting **Department of Transportation (DOT) Safety Towing Regulations**, before towing your trowel. 
- In order to reduce the possibility of an accident while transporting the trowel on public roads, **ALWAYS** make sure the trailer that supports the trowel and the towing vehicle are mechanically sound and in good operating condition.
- **ALWAYS** shutdown engine before transporting
- Make sure the hitch and coupling of the towing vehicle are rated equal to, or greater than the trailer "gross vehicle weight rating."
- **ALWAYS** inspect the hitch and coupling for wear. **NEVER** tow a trailer with defective hitches, couplings, chains, etc.
- Check the tire air pressure on both towing vehicle and trailer. **Trailer tires should be inflated to 50 psi cold.** Also check the tire tread wear on both vehicles.
- **ALWAYS** make sure the trailer is equipped with a **safety chain**.
- **ALWAYS** properly attach trailer's safety chains to towing vehicle.
- **ALWAYS** make sure the vehicle and trailer directional, backup, brake and trailer lights are connected and working properly.
- DOT Requirements include the following:
 - Connect and test electric brake operation.
 - Secure portable power cables in cable tray with tie wraps.
- The maximum speed for highway towing is 55 MPH unless posted otherwise. Recommended off-road towing is not to exceed 15 MPH or less depending on type of terrain.
- Avoid sudden stops and starts. This can cause skidding, or jack-knifing. Smooth, gradual starts and stops will improve towing.
- Avoid sharp turns to prevent rolling.

- Trailer should be adjusted to a level position at all times when towing.
- Raise and lock trailer wheel stand in up position when towing.
- Place **chock blocks** underneath wheel to prevent rolling while parked.
- Place support blocks underneath the trailer's bumper to prevent tipping while parked.
- Use the trailer's swivel jack to adjust the trailer height to a level position while parked.

ENVIRONMENTAL SAFETY

NOTICE

- Dispose of hazardous waste properly. Examples of potentially hazardous waste are used motor oil, fuel and fuel filters. 
- **DO NOT** use food or plastic containers to dispose of hazardous waste.
- **DO NOT** pour waste, oil or fuel directly onto the ground, down a drain or into any water source.

DIMENSIONS/SPECIFICATIONS

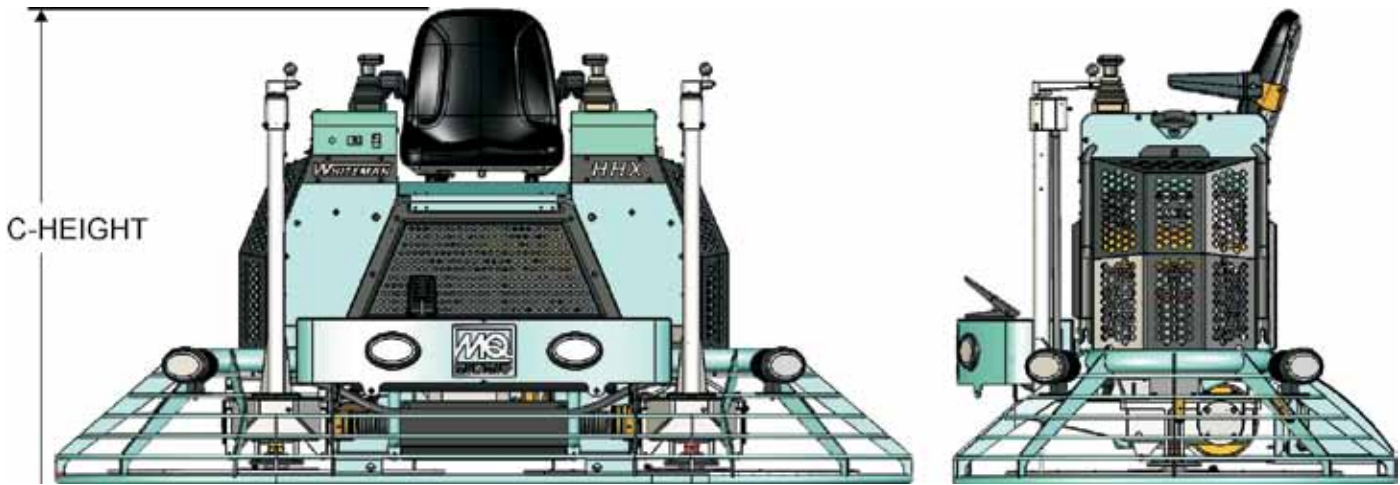

Figure 1. HHX Dimensions

Table 1. HHX Specifications	
SPECIFICATION PARAMETER	HHXD5 (VANGUARD)
A–Length – in. (cm)	98.00 (249)
B–Width – in. (cm)	50.0 (127)
C–Height – in. (cm)	54.0 (137.2)
Weight – lbs. (kgs.) Operating	1,440 (658)
Weight – lbs. (kgs.) Shipping	1,515 (692)
Blade Tip Speed – FPM (m/s)	1425 (7.24)
Fuel Tank – gallons (liters)	9 (34)
Rotor – RPM	40 to 170
Path Width – in. (cm)	91 (231)
Hydraulic Oil4	Whiteman P/N 10139 Or ISO 68 AWMV

SPECIFICATIONS

Table 2. Noise and Vibration Emissions	
Guaranteed ISO 11201:2010 Based Sound Pressure Level at Operator Station in dB(A)	98
Guaranteed ISO 3744:2010 Based Sound Power Level in dB(A)	120
Whole Body Vibration Per ISO 2631-1:1997+A1:2010 in $m/s^2 \sum A(8)$	0.06

NOTES:

1. Sound Pressure and Power Levels are "A" weighted Measures per ISO 226:2003 (ANSI S1.4-1981). They are measured with the operating condition of the machine which generates the most repeatable but highest values of the sound levels. Under normal circumstances, the sound level will vary depending on the condition of the material being worked upon.
2. The vibration level indicated is the vector sum of the RMS (Root Mean Square) Values of amplitudes on each axis, standardized to an 8 hour exposure period, and obtained using operating condition of the machine that generates the most repeatable but highest values in accordance with the applicable standards for the machine.
3. Per EU Directive 2002/44/EC, the daily exposure action value for whole body vibration is $0.5 m/s^2 \sum A(8)$. The daily exposure limit value is $1.15 m/s^2 \sum A(8)$.

Table 3. HHXD5 Engine Specifications	
Model	Vanguard DM950DT
Type	Diesel, Turbo
Cylinders	3
Displacement	58.1 cu.in. (953 cc)
Power (Maximum Output)	31 HP (21.1 kW) @3600 rpm
Bore and Stroke	2.83 in. x 3.07 (72 mm x 78 mm)
Maximum Torque (Intermittent)	72.1 Nm @ 2400 rpm
Compression Ratio	24.8
Cooling System	water-cooled
Engine Oil Capacity	3.2 qt. (3 liters) 3.5 qt. (3.3 liters) w/ oil filter replacement
Lubricating System	Pressure feed with spin-on filter
Fuel Tank	9 gal. (34 liters)
Fuel Delivery System	Direct Injected
Helical Gearbox Gear Compound Capacity	144 oz. (4.26 liters) ISO 220 AGMA GR 5EP
Fuel	Diesel - No. 2-D (ASTM D975) Cetane rating 40 or higher
Starting System	12V Electric Starter with Glow Plug
Dry Weight	196 lbs. (89 Kg)
Dimensions (L x W x H)	17.8 in. x 17.6 in. x 21.2 in (452.6 mm x 447.6 mm x 538 mm).

GENERAL INFORMATION

HHX RIDE-ON TROWEL FAMILARIZATION

The HHX is designed for the floating and finishing of concrete slabs.

Take a walk around your trowel. Take notice of all the major components like the engine, blades, air cleaner, fuel system, fuel shut-off valve, ignition switch etc. Ensure engine and gearbox lubricant levels are within proper operating range and maintain a proper level of hydraulic fluid in the hydraulic fluid reservoir.

Read all the safety instructions carefully. Safety instructions will be found throughout this manual and on the machine. Keep all safety information in good, readable condition. Operators should be well trained on the operation and maintenance of the trowel.

Look at the operator Control Joysticks. Grasp the Control Joysticks and move them around a bit. Observe how moving the Control Joysticks cause the gearboxes and frame to move.

Notice the foot pedal which controls the engine and blade speed. Also take a look at the main driveline of the trowel. Take note and reference how the belts look, this is the way the belts should look when adjusted properly.

Before using your trowel, test it on a flat watered down section of finished concrete. This trial test run will increase your confidence in using the trowel and at the same time it will familiarize you with the trowel's controls and indicators. In addition you will understand how the trowel will handle under actual conditions.

ENGINE HHXD5

The HHXD5 Ride-On Power Trowel is equipped with a liquid cooled 31 HP Vanguard Diesel engine. Refer to the engine owner's manual for specific instructions regarding engine operation. This manual is included with the ride-on trowel at the time of shipping. Please contact your nearest Multiquip Dealer for a replacement should the original manual disappear.

BLADES

The blades of the ride-on power trowel finish the concrete as they are swirled around the surface. Blades are classified as combination (10 or 8 inches wide), finish (6 inches wide). The HHX is equipped with five blades per rotor equally spaced in a radial pattern and attached to a vertical rotating shaft by means of a **spider assembly**.

GEARBOXES

The HHX consist of two separate gearbox assemblies that are enclosed in rugged cast aluminum gear cases.

The gearbox casing holds 50% more oil capacity than competitors, which allows more lubrication to be provided to critical points.

HYDRAULIC STEERING

Dual palm grip joystick controls located to the left and right of the operator are provided for steering the HHX. The joysticks are linked to three hydraulic steering cylinders located within the frame of the machine. Detailed explanation of how the joystick controls affect the steering of the trowel can be found in the Operation section of this manual.

See the steering chart (Table 3) for information on the effect the steering joysticks have upon the steering direction of the machine.

CONSTANT VELOCITY JOINTS (CV-JOINTS)

Constant velocity joints insure the efficient transfer of power to the drive shaft and maintains the timing of the gearboxes without any chance of slippage.

TRAINING

For proper training, please use the "**TRAINING CHECKLIST**" located in the front of this manual. This checklist will provide an outline for an experienced operator to provide training to a new operator.

Figure 2, Figure 3 and Figure 4 show the location of the controls, indicators and general maintenance parts. Each control may perform more than one function.

CONTROLS AND INDICATORS

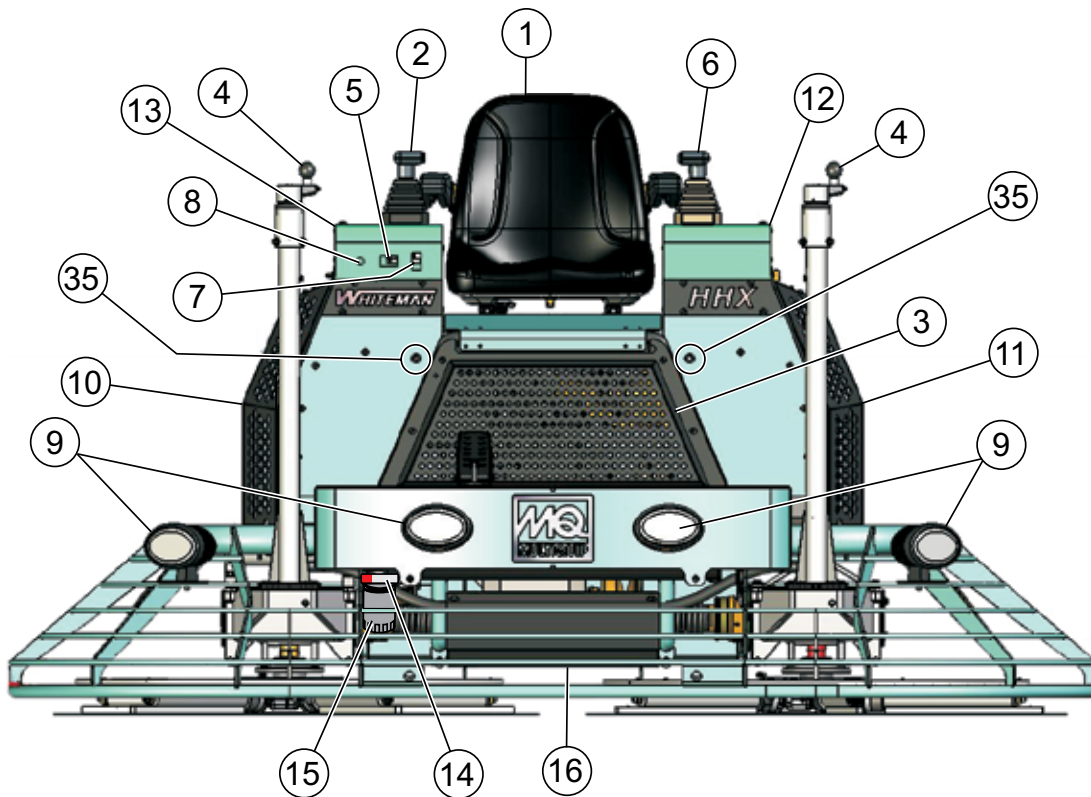

Figure 2. HHXD5 Controls and Indicators (Front)

1. **Seat** — Place for operator to sit. Engine will not start unless operator is seated. Seat is adjustable, fore and aft for operator comfort.
2. **Steering Control Joystick (right side)** — Allows the unit to move in either a forward, reverse left or right direction.
3. **Front Guard** — Remove this Guard Cover to access left side of engine and other internal components.
4. **Pitch Control** — Adjusts the blade pitch separately for each side of the trowel.
5. **Hour Meter** — Indicates number of hours machine has been in use or hours engine was run.
6. **Steering Control Joystick (left side)** — Allows the unit to move in either a forward, reverse left or right direction. See Page 24 for additional Information.
7. **Light Switch** — When activated, turns on four halogen lights. Lights offer better visibility when working indoors.
8. **Ignition Switch** — With key inserted turn clockwise to start engine.
9. **Lights** — 12V Halogen, 4 fore and 2 aft.
10. **Right Side Guard** — Remove to access Radiator and to allow Right Clamshell to open for Service.
11. **Left Side Guard** — Remove to access Battery and to allow Left Clamshell to open for Service.
12. **Left Side Clamshell** — Open to allow access for service and maintenance.
13. **Right Side Clamshell** — Open to allow access for service and maintenance.
14. **By-Pass Indicator** — Sight glass located in-line and just above the Hydraulic By-Pass Filter. System in a By-Pass condition when indicator in the red area.
15. **Hydraulic By-Pass Filter** — Filters contaminants from hydraulic system during a By-Pass condition.
16. **Magnetic Drain Plug** — Remove to drain hydraulic oil from hydraulic system.

CONTROLS AND INDICATORS

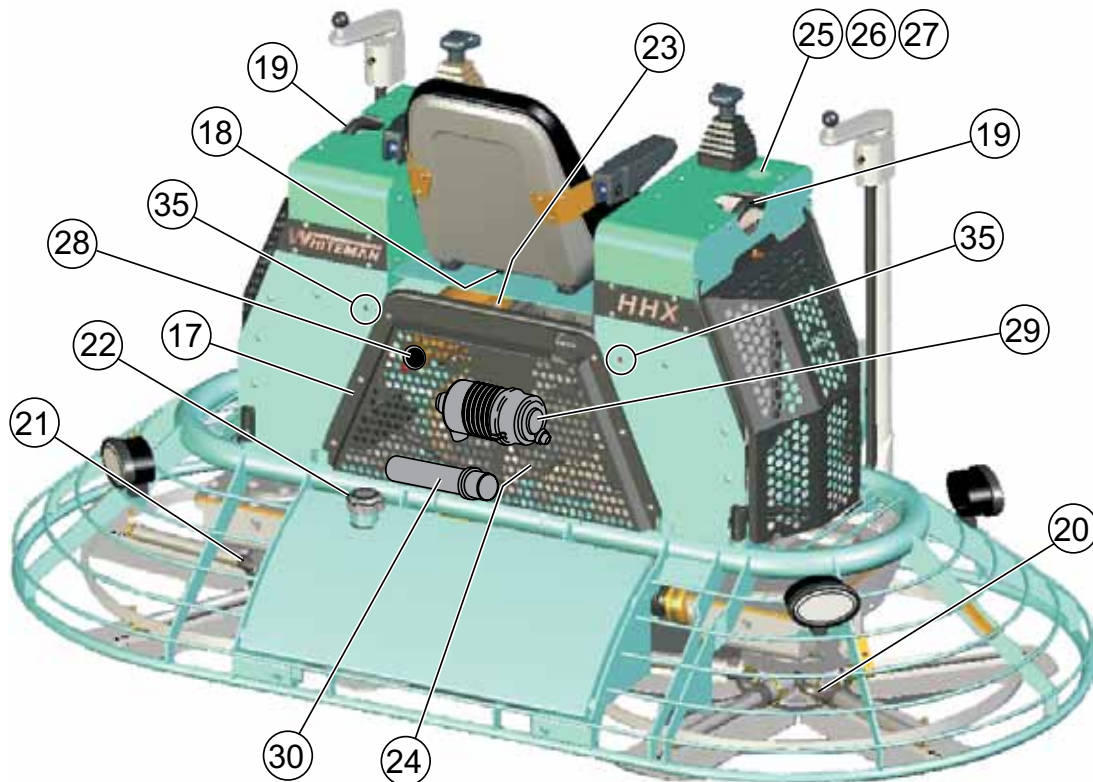

Figure 3. HHXD5 Controls and Indicators (Rear)

17. **Rear Guard** — Remove to access right side of engine and internal components for service and maintenance.
18. **Safety-Stop Switch** — Shuts down engine when operator is not sitting in seat .
19. **Lift Points** — Located on both the left and right sides of the main frame. Used when the trowel must be lifted onto a concrete slab.
20. **Right-Side Spider** — Consists (basic) of trowel arms, blades, wear plate, and thrust collar etc.
21. **Left-Side Spider** — Consists (basic) of trowel arms, blades, wear plate, and thrust collar etc.
22. **Fuel Filler Cap** — Remove this cap to add fuel.
23. **Engine Dip Stick** — Indicates engine oil level. Add oil as required.
24. **Oil Filter** — Provides oil filtering for the engine.
25. **Oil Indicator Light** — Lights red when oil pressure is low.
26. **Water Temperature Light** — Lights red when water temperature is high.
27. **Charge Indicator** — Lights red when electrical system is not charging properly.
28. **Exhaust Outlet** — Exhaust gases routed through muffler and out the back of the rear guard.
29. **Air Filter Assembly** — Helps prevent dirt and debris from entering the fuel system. Lift Locking Latch on cannister to gain access to filter element.
30. **Document Box** — Use to hold and protect Operation Manual.

CONTROLS AND INDICATORS

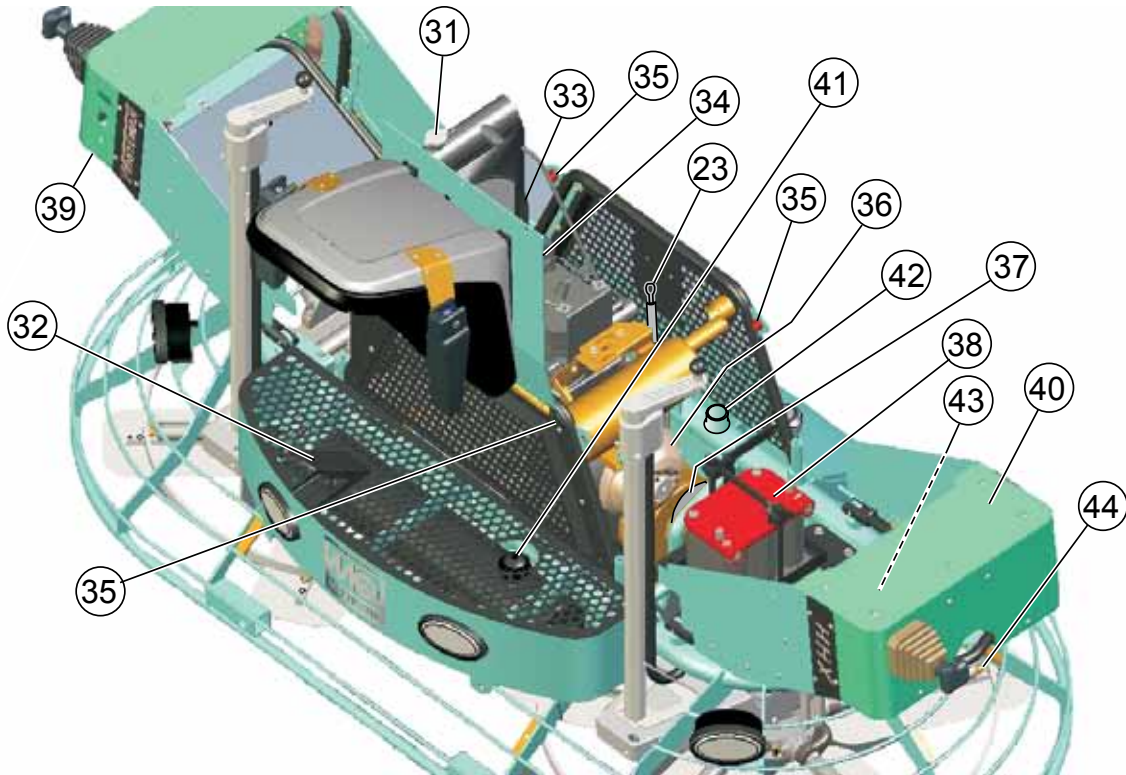

Figure 4. HHXD5 Controls and Indicators (Clamshell Open)

- 31. **Radiator/Filler Cap** — Holds coolant or water necessary to keep engine at a safe operating temperature. Remove this cap to add water or antifreeze.
- 32. **Blade Speed Pedal** — Slow blade speed is accomplished by slightly depressing the foot pedal while maximum blade speed is accomplished by fully depressing the pedal.
- 33. **Overflow Bottle** — Supplies coolant to the radiator when radiator coolant level is low. Fill to indicated level as shown on bottle.
- 34. **Engine Oil Filler Cap** — Remove this cap to add engine oil.
- 35. **Clamshell Securing Bolt Location (4 places)** — Remove to open clamshell.
- 36. **Clutch and Belt** — Drive Pulleys transfer power from the engine to the gearboxes
- 37. **Spare Belt Carrier** — Contains a spare drive belt for expedient belt replacement.
- 38. **Battery** — Provides +12V DC power to the electrical system
- 39. **Right Side Clamshell** — Remove two bolts to open for service and maintenance access.
- 40. **Left Side Clamshell** — Remove two bolts to open for service and maintenance access.
- 41. **Retardant Spray Filler Cap** — Remove this cap to add spray retardant.
- 42. **Burp Tank** — Hydraulic Fluid top-off point.
- 43. **Test Port-Hydraulic Pressure** — Hook test gauge to test port to determine hydraulic pressure during operation.
- 44. **Retardant Spray Control Button** — Located on both joysticks. When pressed, allows retardant spray to flow through the spray nozzle.

The following section is intended as a basic guide to the ride-on trowel operation, and is not to be considered a complete guide to concrete finishing. It is strongly suggested that all operators (experienced and novice) read "Slabs on Grade" published by the American Concrete Institute, Detroit Michigan.

ENGINE COMPONENTS (DIESEL)

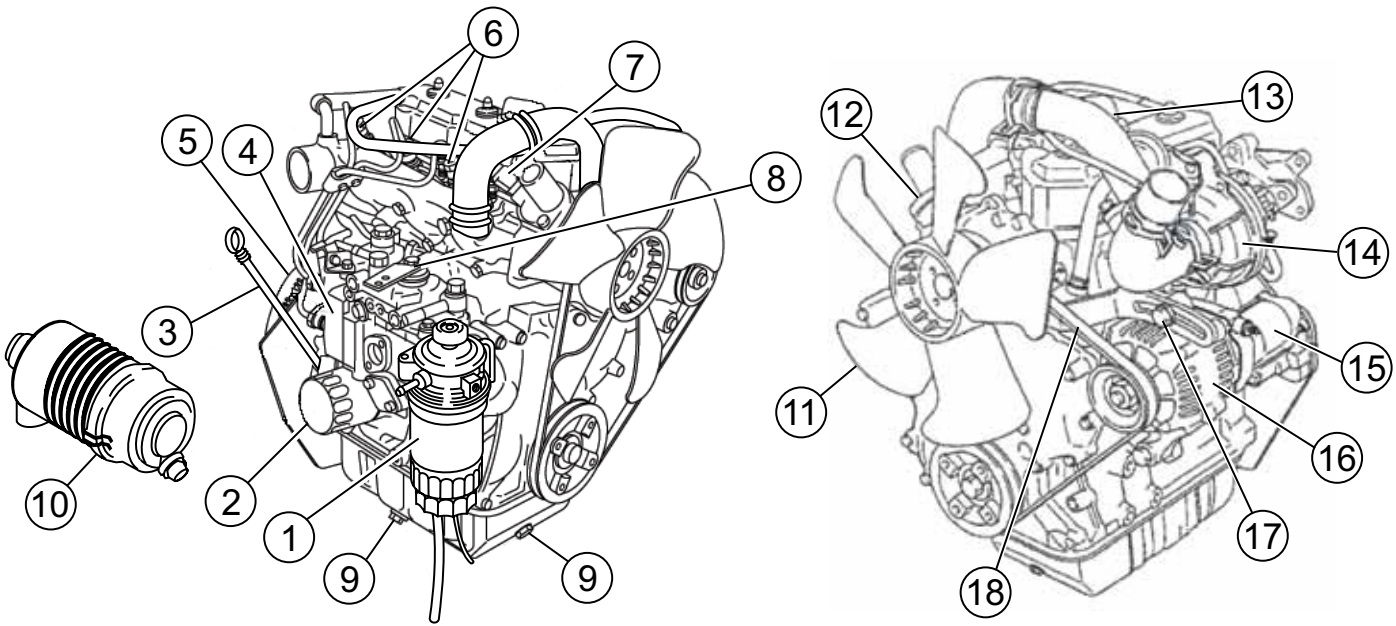

Figure 5. Engine Components (Diesel Engine)

The following refer to the basic engine components for reference (Figure 5). Refer to the manufacturer's engine manual for instructions and details of operation and servicing. The engine shown above is a Briggs & Stratton Vanguard Diesel engine.

1. **Fuel Filter** — Prevents dirt and other debris from entering the Fuel Injection system.
2. **Oil Filter** — Prevents dirt and other debris from entering the engine oil.
3. **Oil Dip Stick** — Remove to check amount and condition of oil in crankcase. Lift Seat to access.
4. **Injector Pump** — Provides constant pressure for fuel delivery to Injectors.
5. **Flywheel** — Mates to hydraulic motor.
6. **Fuel Injectors** — Provides fuel to combustion chambers.
7. **Coolant Temperature Sending Unit** — Device that measures coolant temperature.
8. **Governor Lever** — This lever restricts engine speed (high idle or low idle) through a speed control device linked to the accelerator system.
9. **Oil Drain** — Used to drain crankcase oil. Always dispose of used oil and oil filters in an environmentally safe manner. DO NOT allow used oil to drain onto the ground or into a water runoff drain.
10. **Air Filter** — Prevents dirt and other debris from entering the engine Induction system.
11. **Fan** — Provides cooling air to the radiator.
12. **Coolant Inlet** — Circulates coolant fluid via radiator.
13. **Oil Filler Cap** — Remove to add engine oil.
14. **Turbocharger** — Provides additional power over naturally aspirated units..
15. **Electric Starter** — Starts engine when ignition key is rotated to the "START" position.
16. **Alternator** — Provides current to the electrical system and charges the battery.
17. **Belt Tensioning Bolt** — Loosen to tension fan belt.
18. **Fan Belt** — Replace if frayed or worn.

WARNING



Engine components can generate extreme heat. To prevent burns, **DO NOT** touch these areas while the engine is running or immediately after operating. **NEVER** operate the engine with the muffler removed.

TROWEL SETUP INSTRUCTIONS

The purpose of this section is to assist the user in the setting up of a **NEW** trowel. If your trowel is already assembled (seats, handles, knobs and battery), then this section can be skipped.

NOTICE

The new ride-on trowel cannot be put into service until the setup installation instructions are completed. These setup instructions only need to be performed at the time of unpacking a **NEW** trowel.

Before packaging and shipping this Whiteman Ride-On Power Trowel, it was run and tested at the factory. If there are problems with the trowel, please let us know.

NOTICE

HHX trowels have a seat that is mounted on tracks, similar to an automobile seat. This seat can be adjusted fore and aft via the Control Joystick under the front of the seat.

BATTERY SETUP

This trowel was shipped with a wet charged battery. This battery may need to be charged for a brief period of time as per the manufacturer instructions.

To install the battery on the trowel, make sure that the battery is well seated in the battery box and the terminals are properly connected. The positive cable, normally red, is associated with the "+" symbol on the battery. The negative cable, normally black, is associated with the "-" symbol on the battery, (Figure 6). Connect the positive cable to the positive terminal on the battery first, then connect the negative cable to the negative terminal. Close the plastic battery box cover and secure the battery box.

⚠ DANGER

Use all safety precautions specified by the battery manufacturer when working with the battery.



Flammable, explosive gas. (produces hydrogen gas while charging or during operation). Keep area around battery well ventilated and keep from any fire source.

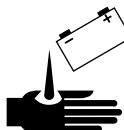

Battery electrolyte contains corrosive, toxic chemical. (dilute sulfuric acid). Avoid contact with eyes and skin.



Shock or Fire due to electric short-circuit. Disconnect battery cables before inspecting electrical system and never "spark" battery terminals to test for charge.

NOTICE

ALWAYS be sure the battery cables are properly connected to the battery terminal. The **RED** cable is connected to the positive terminal of the battery, and the **BLACK** cable is connected to the negative terminal of the battery.

⚠ CAUTION

Use all safety precautions specified by the battery manufacturer when working with the battery. See further specific safety information on page 11 of this manual.

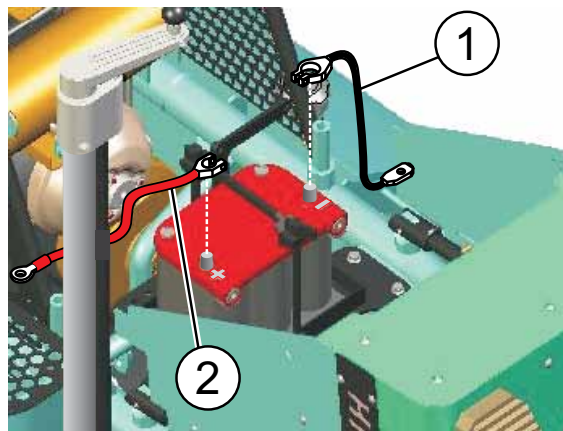

Figure 6. Battery Cable Orientation

INSPECTION

This section is intended to assist the operator with the initial start-up of the HHX. It is extremely important that this section be read carefully before attempting to use the trowel in the field.

DO NOT use your ride-on power trowel until this section is thoroughly understood.

WARNING

Failure to understand the operation of the HHX could result in severe damage to the trowel or personal injury.

See Figure 2, Figure 3 and Figure 4 for the location of any control or indicator referenced in this manual.

ENGINE OIL LEVEL

1. Lift (tilt) seat forward to access dipstick.
2. Pull the engine oil dipstick from its holder.
3. Determine if engine oil is low (Figure 7), add correct amount of engine oil to bring oil level to a normal safe level (See Recommended Viscosity Grades, Table 5)..

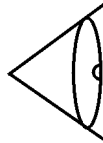

CAUTION

DO NOT overfill engine oil. Oil level should not be above the top fill line.

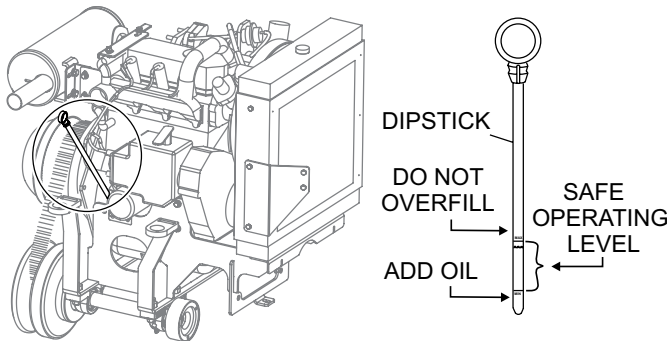
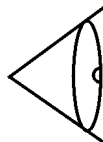

Figure 7. Engine Oil Dipstick

GEARBOX OIL LEVEL

1. Check the gearbox oil level in both gearboxes by viewing the sight glass at the rear of the gearbox. See Figure 8.
2. The oil level of the gear box should be at the half-way point of the sight glass (Figure 8). The gear



box oil capacity is 1 U.S. Gallon, (3.79 liters). If additional oil is required, unscrew the oil fill plug located on top of the gearbox, and refill with ISO 220 A GMA GR 5 EP oil.

FILL PLUG

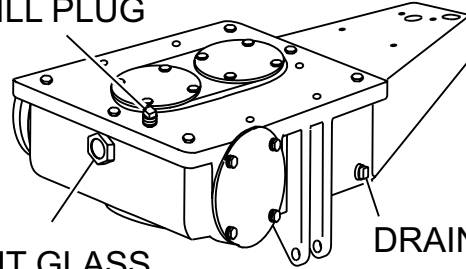

SIGHT GLASS
(OIL CHECK)

DRAIN PLUG

Figure 8. Gearbox Oil Plugs

FUEL

To determine if the engine fuel is low, view the sight gauge on the side of the fuel tank. If fuel level is low, fill with clean Diesel fuel.

WARNING

Handle fuel safely. Motor fuels are highly flammable and can be dangerous if mishandled. **DO NOT** smoke while refueling. Do not attempt to refuel the ride-on trowel if the engine is hot or running.

WARNING

Never store the ride-on trowel with fuel in the tank for any extended period of time. Drain fuel into an appropriate receptacle. Drain by opening the fuel petcock at the bottom of the tank. Always clean up spilled fuel immediately.

HYDRAULIC FLUID FILTER

To determine if the hydraulic fluid filter needs to be changed, view the sight gauge above the hydraulic filter located beneath the foot platform.. If the gauge reads in the red area, indicating a filter by-pass condition, the filter needs to be replaced.

STARTING THE ENGINE

1. Place one foot on the trowel's platform, grab a hold of any part of the frame (NOT THE JOYSTICKS), lift yourself onto the trowel, then sit down in the operator's seat.

NOTICE

The HHX is equipped with a safety stop switch that will not allow the engine to start unless an operator is sitting in the operator's seat. The weight of an operator depresses an electrical switch, which allows the engine to start.

WARNING

NEVER disable or disconnect the safety stop switch. It is provided for the operator's safety and injury may result if it is disabled, disconnected or improperly maintained.

NOTICE

The safety stop switch should be used to stop the engine after every use. Doing this will verify the switch is working properly thus providing safety for the operator. Remember to turn the key to the "OFF" position after stopping the machine. Not doing so may drain the battery.

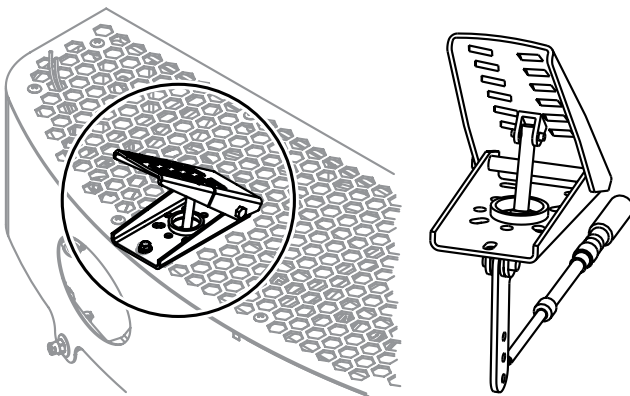

Figure 9. Blade Speed Control Foot Pedal

2. The foot pedal (Figure 9) controls blade and engine speed. The position of the foot pedal determines the blade speed. Slow blade speed is obtained by slightly depressing the pedal. Maximum blade speed is obtained by fully depressing the pedal.

3. Keep your foot **OFF** the foot pedal. If the engine is cold, adjust the choke but in all circumstances, start the engine at idle (without touching foot pedal).
4. Insert the **ignition key** into the ignition switch .
5. Turn the ignition key clockwise to the (start) position. The **oil** and **charge** indicator lights, (Figure 10) should be on

NOTICE

OIL, and CHARGE, indicator lights come on when ignition switch is in the ON position, and the engine is NOT running. In COLD weather turn and hold the ignition key counter clockwise to the PREHEAT position, wait until the preheat indicator goes off before turning the ignition key clockwise to the start position. Two or three preheat cycles may be necessary in very cold weather.

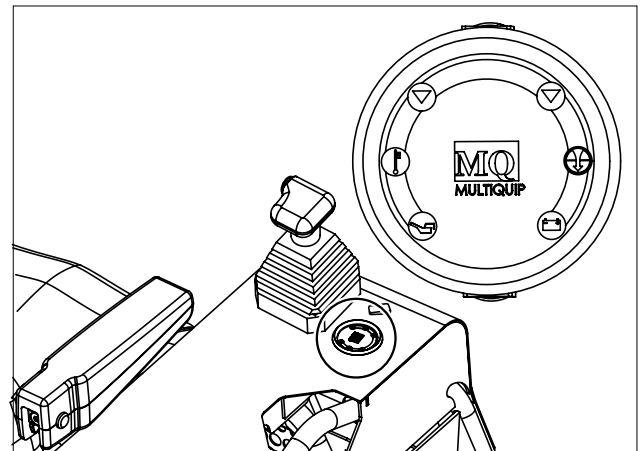

Figure 10. Oil and Charge Indicator Lights

6. Turn ignition key fully clockwise and listen for engine to start. Once engine has started release ignition key.
7. If the engine fails to start in this manner, consult the engine owner's manual supplied with the trowel.
8. Test the safety kill switch by standing up briefly. The switch under the seat should cause the engine to stop. If the kill switch fails to shut down the engine. Turn off the engine with the key switch and fix the safety kill switch. See Troubleshooting Chart for possible problems.

- Repeat this section a few times to get fully acquainted with the engine starting procedure.
- Let the engine idle for 3-5 minutes. If choke is applied, push the choke to the open position as soon as the engine will run smoothly.

STEERING

Two joysticks (Figure 11) located to the left and right of the operator's seat provide directional control for the HHX Ride-On Power Trowel. Table 4 illustrates the various directional positions of the joysticks and their effect on the ride-on trowel.

NOTICE
All directional references with respect to the steering Control Joysticks are from the **operator's** seat position.

- Push both the left and right Control Joysticks forward. See Figure 11.

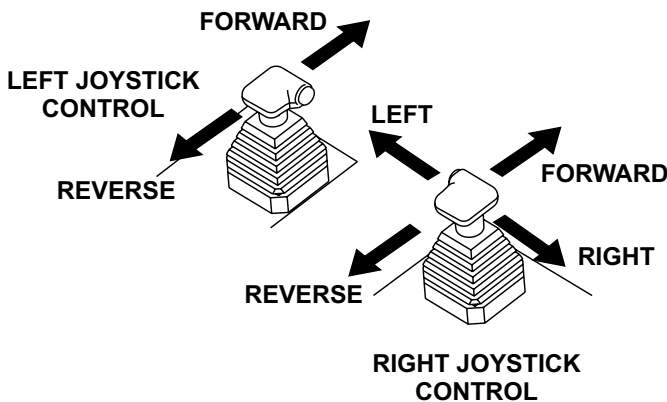

Figure 11. Left and Right Control Joysticks

- With your right foot quickly depress the right foot pedal halfway. Notice that the ride-on power trowel begins to move in a forward direction. Return both joystick controls to their neutral position to stop forward movement, then remove your right foot from the right foot pedal.
- Practice holding the machine in one place as you increase blade speed. When about 75% of maximum blade speed has been reached, the blade will be moving at proper finishing speed. The machine may be difficult to keep in one place. Trying to keep the ride-on trowel stationary is a good practice for operation.

- Practice maneuvering the ride-on trowel using the information listed in Table 4. Try to practice controlled motions as if you were finishing a slab of concrete. Practice edging and covering a large area.
- Try adjusting the pitch of the blades. This can be done with the ride-on trowel stopped or while the trowel is moving, whatever feels comfortable. Test the operation of optional equipment like retardant spray and lights if equipped.
- Push both the left and right joysticks backward and repeat steps 3 through 6 while substituting the word reverse for forward.

Table 4. Control Joystick Directional Positioning	
CONTROL JOYSTICK & DIRECTION	RESULT
Move LEFT Joystick FORWARD ↑	Causes only the left side of the ride-on trowel to move forward.
Move LEFT Joystick BACKWARD ↓	Causes only the left side of the ride-on trowel to move backward.
Move RIGHT Joystick FORWARD ↑	Causes only the right side of the ride-on trowel to move forward.
Move RIGHT Joystick BACKWARD ↓	Causes only the right side of the ride-on trowel to move backward.
Move BOTH Joysticks FORWARD ↑ ↑	Causes the ride-on trowel to move forward in a straight line. ↑ ↑
Move BOTH Joysticks BACKWARD ↓ ↓	Causes the ride-on trowel to move backward in a straight line. ↓ ↓
Move BOTH Joysticks to the RIGHT → →	Causes the ride-on trowel to move to the right. → →
Move BOTH Joysticks to the LEFT ← ←	Causes the ride-on trowel to move to the left. ← ←

Blade Pitch

Sometimes it may be necessary to match blade pitch between the two sets of blades. There are some signs that this may be necessary. For example, the differences in pitch could cause a noticeable difference in finish quality between the two sets of blades. Or, the difference in blade pitch could make the machine difficult to control. This is due to the surface area in contact with the concrete (the blade set with the greater contact area tends to stick to the concrete more).

Matching Blade Pitch for Both Sets of Blades

Trowels equipped with Twin Pitch™ Controls may need to have blade pitch between the two sets of blades "synchronized". If the blades need to be synchronized this is easily accomplished by performing the following. Refer to Figure 12.

⚠ CAUTION

When turning an adjustment handle, do not force it to turn or damage to the cable may occur. If the cable starts to noticeably twist this is a good indication that one side is either all ready at full pitch or it is bound up due to concrete, debris, or corrosion.

1. Lift the pitch adjustment handle on either side. Once lifted, that side is now disconnected from the Twin Pitch™ system.
2. Adjust to match the opposite side.
3. When adjusted, lower the handle to Twin Pitch™ operating position.

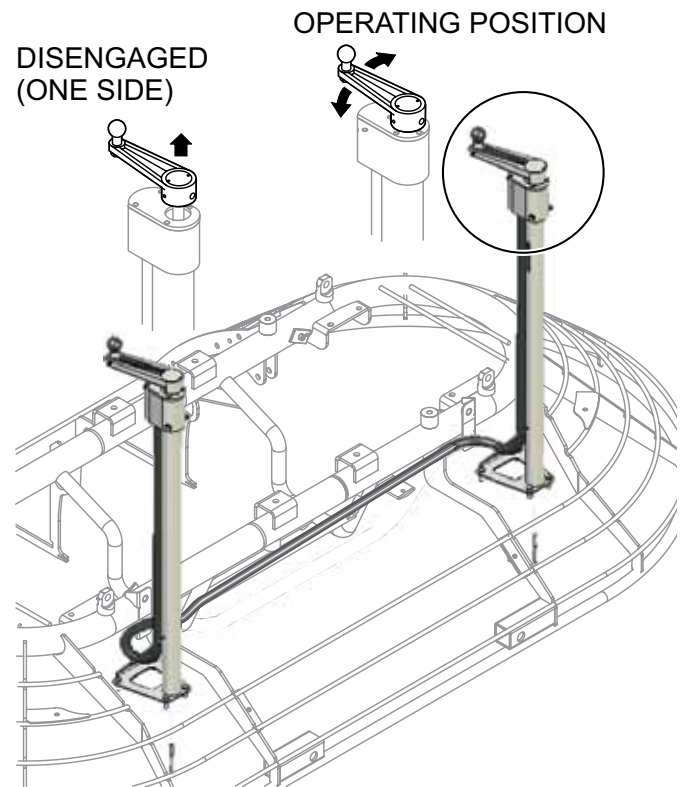



Figure 12. Pitch Tower

MAINTENANCE

When performing any maintenance on the trowel or engine, follow all safety messages and rules for safe operation stated at the beginning of this manual. See the engine manual supplied with your machine for appropriate engine maintenance schedule and troubleshooting guide for problems.

At the front of the book there is a “Daily Pre-Operation Checklist”. Make copies of this checklist and use it on a daily basis.

⚠ WARNING



Accidental starts can cause severe injury or death.



ALWAYS place the ON/OFF switch in the OFF position.



Disconnect and ground spark plug leads and disconnect negative battery cable from battery before servicing.

MAINTENANCE SCHEDULE

Daily (8-10 Hours)

1. Thoroughly remove dirt and oil from the engine and control area. Check for oil or coolant leaks.
2. Check the fluid levels in the engine and gearboxes, fill as necessary. Check air filter. See section on air filter servicing.

Weekly (30-40 Hours)

1. Relube arms, thrust collar and steering links.
2. Replace blades if necessary.
3. Check and clean or replace the engine air filter as necessary. (See following section on Air Filter Maintenance.)

4. Replace engine oil and filter as necessary. (See following section on Oil and Filter)
5. Check and retighten all fasteners as necessary.

Monthly (100-150 Hours)

1. Remove, clean, reinstall and relube the arms and thrust collar. Adjust the blade arms.
2. Replace gearbox lubricant after the first 100 hours of operation. Replace every 500-600 hours.
3. Check drive belt for excessive wear.
4. Replace engine oil and filter as necessary, see engine manual.

Yearly (500-600 Hours)

1. Check the arm bushings, thrust collar bushings, shaft seals and belts. Replace if necessary
2. Check pitch control cables for wear.
3. Replace gearbox lubricant.
4. Check and adjust blade speed.
5. Change fuel filter element..

					30				
				10W-30	10W-40	10W-50			
			5W-30	*					
°F	-30	-10	10	32	50	70	90	110	
°C	-34	-23	-12	0	10	21	32	43	
STARTING TEMPERATURE RANGE ANTICIPATED BEFORE NEXT OIL CHANGE									

* A synthetic 5W-30 oil may be used.

⚠ WARNING

Certain maintenance operations or machine adjustments require specialized knowledge and skill. Attempting to perform maintenance operations or adjustments without the proper knowledge, skills or training could result in equipment damage or injury to personnel. If in doubt, consult your dealer.

Air Cleaner (Daily)

The Briggs and Stratton Vanguard engine is equipped with a replaceable, high-density paper air cleaner element. Check the air cleaner daily or before starting the engine. Check for and correct heavy buildup of dirt and debris along with loose or damaged components, (Figure 13).

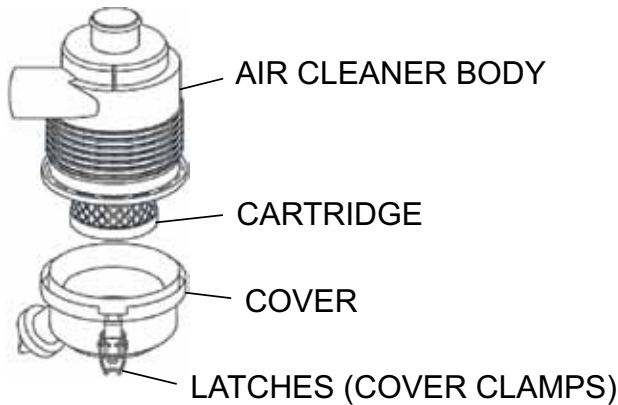

Figure 13. Air Cleaner

1. Unlock the cover clamps (4) and remove cover (3).
2. Remove cartridge (2) from air cleaner body (1).
3. Clean cartridge by gently tapping the end with the handle of a screwdriver. Replace cartridge if very dirty or damaged.
4. Carefully clean out the air cleaner cover.
5. Install cartridge in body.
6. Install cover and lock cover clamps.

NOTICE

Operating the engine with loose or damaged air cleaner components could allow unfiltered air into the engine causing premature wear and failure.

Changing Engine Oil And Filter

1. Change the engine oil and filter after the first 5 hours of use, then change oil every 6 months or 150 hours.
2. Remove the oil filler cap and fill engine crankcase with recommended viscosity grade oil as listed in Table 5.

Use high quality detergent oil classified "For Service CF, or CF-4". Fill to the upper limit of dipstick. Do not over-fill.

3. Crankcase oil capacity with oil filter replacement is 3.5 qts. (3.3 liters).

Oil Filter (300 Hours)

1. Replace the engine oil filter (Figure 14) every other oil change or 300 hours. Refer to your engine manual for specific details to perform this operation.

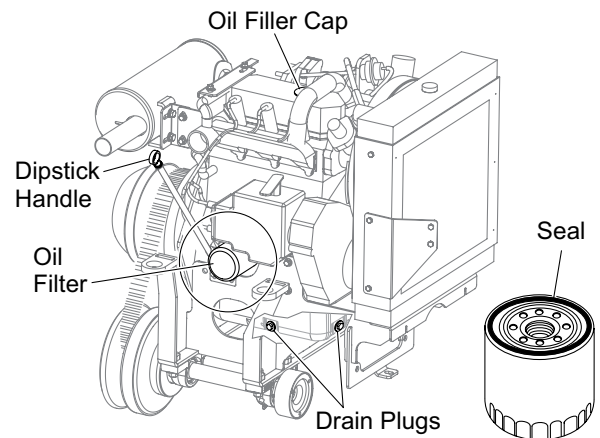

Figure 14. Oil Filter Replacement

2. Be sure to coat the seal (Figure 14) of the new oil filter with clean engine oil.

Fuel Filter

- Replace the engine fuel filter (Figure 15) every 800 hours. Refer to your engine manual for specific details to perform this operation.

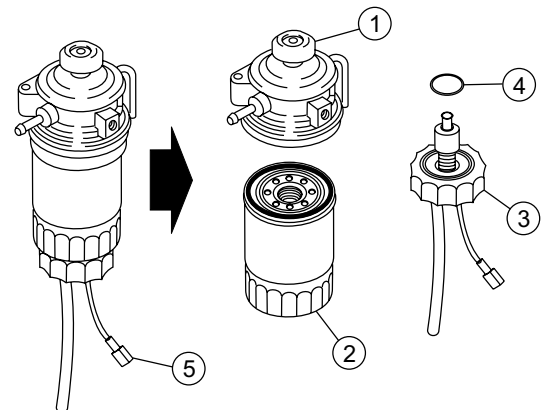

Figure 15. Fuel Filter

Oil/Water Separator

Drain water from the bottom of the fuel filter by loosening the drain plug and allowing the water to drain out. Refer to your engine manual for specific details to perform this operation.

Oil And Fuel Lines

1. Check the oil and fuel lines and connections regularly for leaks or damage. Repair or replace as necessary.
2. Replace the oil and fuel lines every two years to maintain the line's performance and flexibility.

Radiator/Cooling System

WARNING

Hot coolant can cause severe burns. DO NOT remove cap if radiator is HOT.

1. Check and clean radiator fins.
2. Check cooling water.
3. Check radiator hoses for fatigue or cracking.
4. Check radiator cap seal.

Battery/Charging System

DANGER

Use all safety precautions specified by the battery manufacturer when working with the battery.



Flammable, explosive gas. (produces hydrogen gas while charging or during operation). Keep area around battery well ventilated and keep from any fire source.



Battery electrolyte contains corrosive, toxic chemical. (dilute sulfuric acid). Avoid contact with eyes and skin.



Shock or Fire due to electric short-circuit. Disconnect battery cables before inspecting electrical system and never "spark" battery terminals to test for charge.

1. Check and clean battery terminals for corrosion.
2. Check and keep battery electrolyte between upper and lower limits indicated on the battery. Never operate or recharge without sufficient fluid in the battery.
3. Never attempt to charge a battery that is frozen. The battery can explode unless first allowed to thaw.
4. Disconnect the negative terminal (-) of the battery during storage. If unit will be stored where ambient temperature will drop to -15°C or less, remove and store battery in a warm, dry place.

Long Term Storage

- Remove the battery.
- Drain fuel from fuel tank.
- Clean exterior with a cloth soaked in clean oil.
- Store unit covered with plastic sheet in moisture and dust-free location out of direct sunlight.

CAUTION

Never store the ride-on trowel with fuel in the tank for any extended period of time. Always clean up spilled fuel immediately.

Engine Tune-Up

See your engine manual for specific information on tuning up your engine.

NOTICE

See the engine manual supplied with your machine for appropriate engine maintenance schedule and troubleshooting guide for problems.

CAUTION

ALWAYS disconnect battery cables before attempting any service or maintenance on the ride-on trowel.

MAINTENANCE (OLD STYLE CLUTCH)

NOTICE

This section is intended to aid users in the maintenance of drive assemblies with an old style Comet clutch.

Checking The Drive Belt

The drive belt needs to be changed as soon as it begins to show signs of wear. **DO NOT** reuse a belt under any circumstances. Indications of excessive belt wear are fraying, squealing when in use, belts that emit smoke or a burning rubber smell when in use.

Under normal operating conditions, a drive belt may last approximately 150 hours. If your trowel is not reaching this kind of life span for drive belt wear, check the drive belt for proper pulley alignment and spacing .

To gain access to the drive belt, remove left-side end-grate and open left "Clamshell", then visually inspect the drive belt for signs of damage or excessive wear. If the drive belt is worn or damaged, replace the drive belt

- A 3/4 X 1 X 3-1/4 inch wooden block may assist in helping to hold the lower pulley apart during removal and replacement of belt).

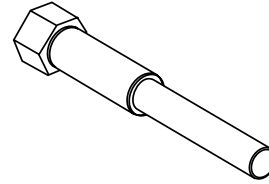

Figure 16. Upper Clutch (Drive Pulley) Removal Tool

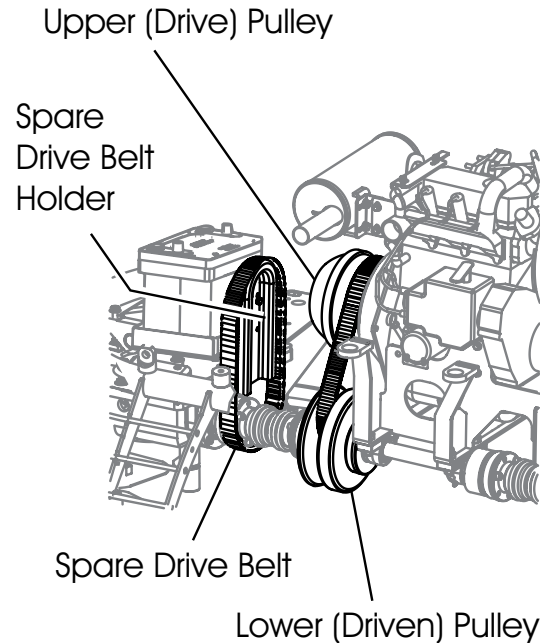

Figure 17. Drive Belt, Belt Holder and Pulleys

1. Remove Left-side End Grate and open Left "Clamshell" (see Figure 4) to gain access to Drive Belt, Spare Drive Belt, and Pulleys (Figure 17) Squeeze the drive belt as shown in Figure 18, and pull the V-belt upwards. This will spread open the faces of the lower drive pulley.

WARNING



DO NOT attempt to insert hands or tools into the belt area while the engine is running and the safety guard has been removed. Keep fingers, hands, hair and clothing away from all moving parts to prevent bodily injury.

WARNING



Allow the entire trowel to cool down before performing this procedure.

Removing the Drive Belt

- Leave the existing drive belt intact until instructed to cut it.
- Leave the engine in place for this procedure. It is not necessary to slide the engine to replace the drive belt.
- Locate the Clutch Removal Tool provided with the trowel, p/n 23294 located within the documentation box. (Figure 16)

MAINTENANCE (OLD STYLE CLUTCH)

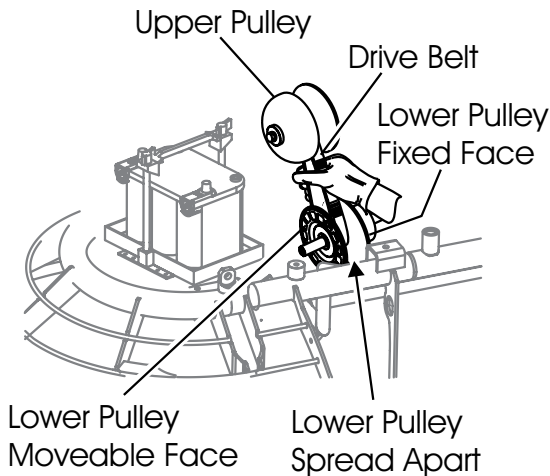

Figure 18. Expanding Lower Drive Pulley

2. A wooden block inserted between the moveable face and the fixed face of the lower drive pulley may help keep the lower drive pulley faces open while installing the new drive belt. See Figure 19.

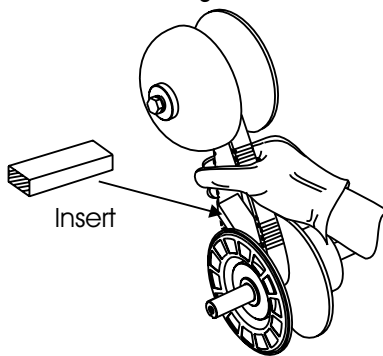

Figure 19. Holding Lower Pulley Open

3. If the belt is not being reused (recommended), CUT the drive belt. Ensure all belt remnants are removed from the pulleys.

Installing the Drive Belt (Using New Drive Belt)

The HHX is equipped with a replacement drive belt (spare) carrier, which is mounted on the inboard side of the platform between the battery and the clutch. Make sure that there is ALWAYS a spare drive belt in the drive belt carrier before the trowel is placed on a slab to finish concrete.

In the event of a drive belt failure, the spare (replacement) drive belt can be used for quick replacement at the job site to continue trowel operation.

1. If necessary, refer to Removing Drive Belt Instructions. Ensure all remnants of old belt have been removed from pulleys.
2. Remove the 2 bolts that secure the drive belt carrier. (Figure 20) This will allow free movement of the belt for installation. Take care with to not contaminate the replacement belt with grease or dirt.
3. Remove the 5/8 Bolt from the Upper Drive Pulley. You will need to hold the flywheel in place by using a large flat blade screwdriver or suitable pry bar.
4. Again hold the flywheel in place as above and thread the Special Upper Drive Pulley Removal Tool (Figure 16), into the Upper Drive Pulley. Tighten until the taperlock breaks free. Slide the pulley off the shaft.
5. Place the replacement belt into the lower pulley first. (A wood block may help holding the lower pulley open).
6. Place the other end of the belt over the upper drive pulley into the pulley groove and slide the pulley back onto the tapered shaft.
7. Use threadlock, (Loctite Blue 246) on 5/8" retaining bolt, thread into pulley and tighten.
8. Reinstall the spare belt carrier and the drive belt guard.
9. Replace the spare belt before the next trowel use. See spare drive belt replacement procedures.

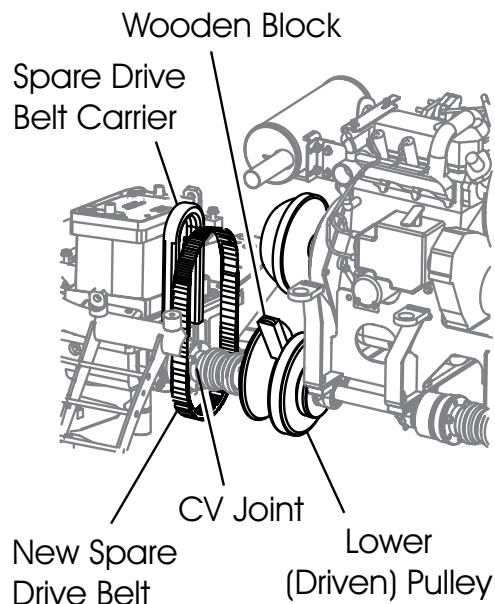

Figure 20. Drive Belt Install

MAINTENANCE (OLD STYLE CLUTCH)

Spare Drive Belt Replacement

To replace a spare drive belt, be prepared to disconnect the CV-joint from the left-side gearbox. See Figure 21.

NOTICE

It will be necessary to disconnect the CV-Joint from the left-side gearbox coupler. This means the removal of the three screws that secure the CV-Joint to the gearbox.

1. Place the trowel on suitable supports and observe all safety precautions.
2. Remove Left-side End Grate and open Left "Clamshell"
3. Remove the three screws that secure the CV-joint to the left-side gearbox coupler.
4. Once the CV-joint has been separated from the left-side gearbox, push the CV-joint inward so that a gap exists between the gearbox and the CV-joint (Figure 21). Slide the spare V-belt between the gearbox coupler and the CV-joint. Avoid contaminating the replacement belt with grease or oil when sliding it between the CV-Joint and gearbox coupler.
5. Place the spare drive belt inside the drive belt carrier, and secure the spare belt carrier to the inboard side of the left gearbox.
6. Install the three screws that secure the CV-joint to the left-side gearbox coupler.

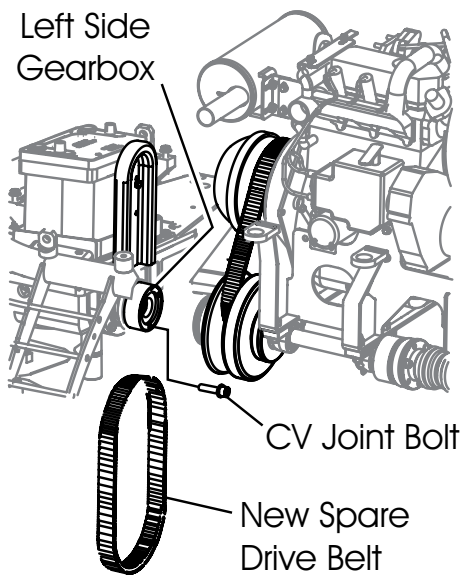

Figure 21. Spare Drive Belt Replacement

The HHX is equipped with a "CVT" type clutch which supplies torque to both the left and right gear boxes.

The function of the CVT, (Continuously Variable Transmission), is to automatically deliver the correct amount of torque required by the trowel under all load conditions. This enables the trowel to deliver the necessary torque for float pan applications and the high rotor speeds required for burnishing concrete.

The Driven Pulley is a variable pitch pulley type, (Figure 22) connected by a drive belt.

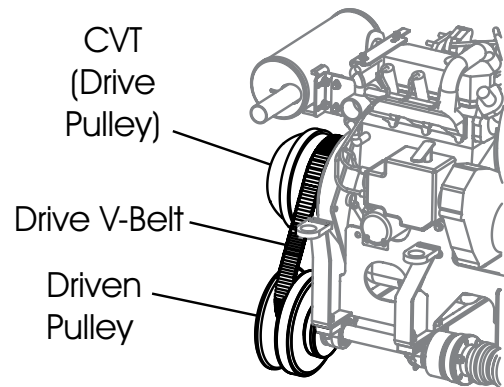

Figure 22. CVT with Variable Pitch Drive Pulley

The Drive Pulley uses centrifugal force (Figure 23 and Figure 24) to create a belt squeeze force transmitted at the pulley faces. This condition functions as an automatic clutch.

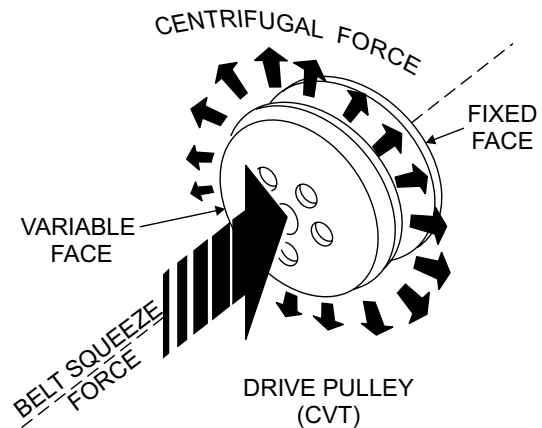

Figure 23. Drive Pulley (Centrifugal Force)

Centrifugal force pushes the roller arms (see Figure 24) against the ramp plate, forcing moveable face toward fixed face squeezing belt.

MAINTENANCE (OLD STYLE CLUTCH)

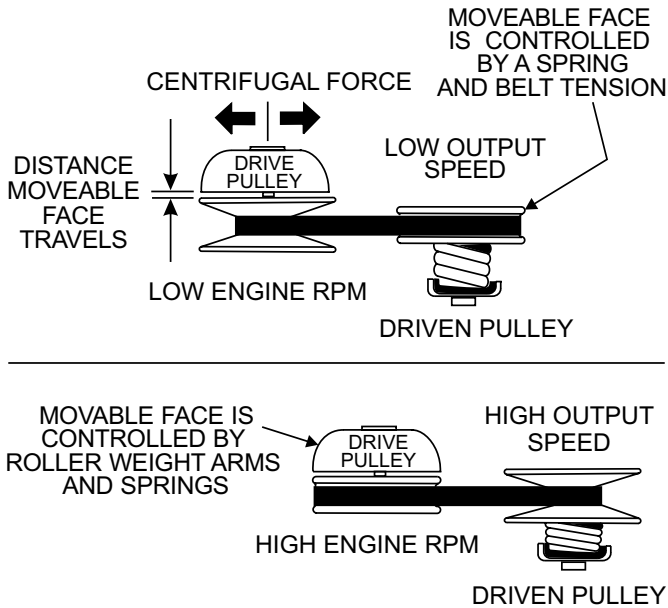

Figure 24. Pulley Interaction

The "Variable Pitch Pulleys" have one fixed face, and one moveable face. The drive pulley moveable face is controlled by roller weight arms and springs, which change position according to engine speed. The driven pulley moveable face is controlled by a spring and belt tension. (Figure 25)

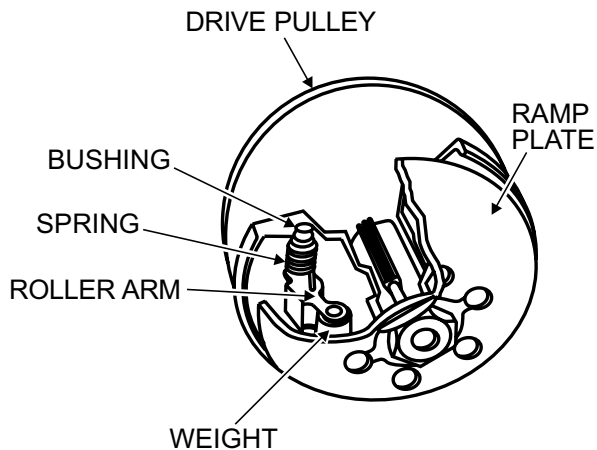

Figure 25. Variable Pitch Pulley

How It Works (Figure 26)

■ Condition A:

- Engine Idling
- Drive Pulley: Small
- Driven Pulley: Large
- Belt: Loose and Stationary

■ Condition B:

- Engine Accelerating
- Drive Pulley: Small But Increasing
- Driven Pulley: Large But Decreasing
- Belt: Approaching Tightness

■ Condition C:

- Engine At High Speed
- Drive Pulley: Large
- Driven Pulley: Small
- Belt: Tight

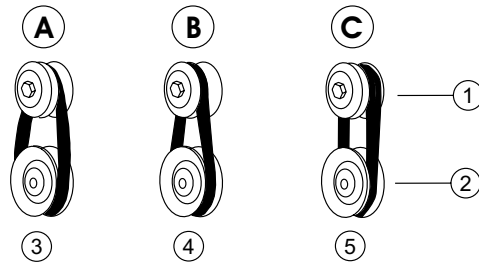

Figure 26. Pulley Conditions

MAINTENANCE (OLD STYLE CLUTCH)

Clutch

This clutch system provides a high pulley ratio (a low gear- so to speak) to start out and a low pulley ratio (a high gear- so to speak) for a high speed operation, with infinite variation between the two.

This means that it will not be necessary to give full throttle in order to "break the blades/pans loose". The machine can slowly be brought up to speed.

The torque sensitive pulley (Figure 27) utilizes a spring and cam bracket. Peak performance results from proper interaction between the driven pulley spring and the ramp angle of the cam bracket.

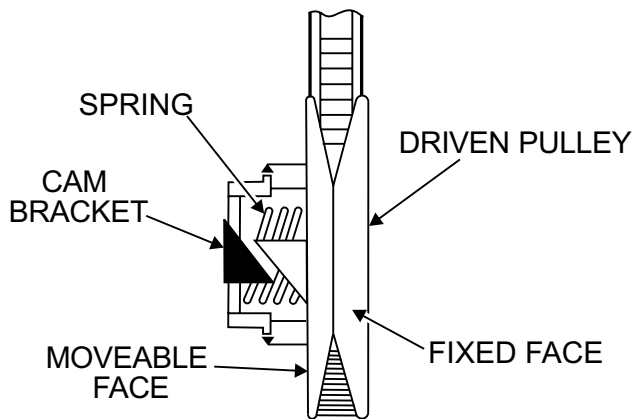

Figure 27. Pulley Spring and Cam Bracket

NOTICE

If replacement of the clutch is required, use clutch replacement kit, P/N 23447, to upgrade to Multi-Clutch system. New style drive assembly must be installed per instruction sheet, P/N 23448, included with clutch replacement kit.

Old style Comet clutch is no longer available. Multi-Clutch components are not interchangeable with the prior Hoffco Comet drive system. The Hoffco Comet CVT system must be replaced for combatibility with the new equipment.

MAINTENANCE (NEW STYLE CLUTCH)

NOTICE

This section is intended to aid users in the maintenance of drive assemblies with a new style Multi-Clutch.

CHECKING THE DRIVE BELT

The drive belt needs to be changed as soon as it begins to show signs of wear. **DO NOT** reuse a belt under any circumstances. Indications of excessive belt wear are fraying, squealing when in use, belts that emit smoke or a burning rubber smell when in use.

To gain access to the drive belt, remove the drive belt guard cover, then visually inspect the drive belt for signs of damage or excessive wear. If the drive belt is worn or damaged, replace the drive belt.

WARNING



DO NOT attempt to insert hands or tools into the belt area while the engine is running and the safety guard has been removed. Keep fingers, hands, hair and clothing away from all moving parts to prevent bodily injury.

WARNING



DO NOT remove the V-belt guard cover until the muffler has cooled. Allow the entire trowel to cool down before performing this procedure.

BELT MEASUREMENT

Long life can be expected with this new drive assembly as long as the belt is kept properly aligned.

The clutch will not shift correctly if the belt width is below 1.14". Measure the CVT belt every 100 hours of use to make sure it is within the specified tolerance. See Figure 28.

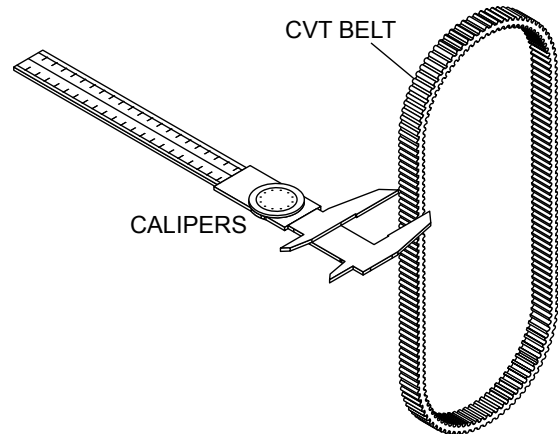

Figure 28. Belt Measurement

REMOVING THE DRIVE BELT

1. Remove Left-side End Grate and open Left "Clamshell" (see Figure 4) to gain access to Drive Belt and Pulleys (Figure 29)..

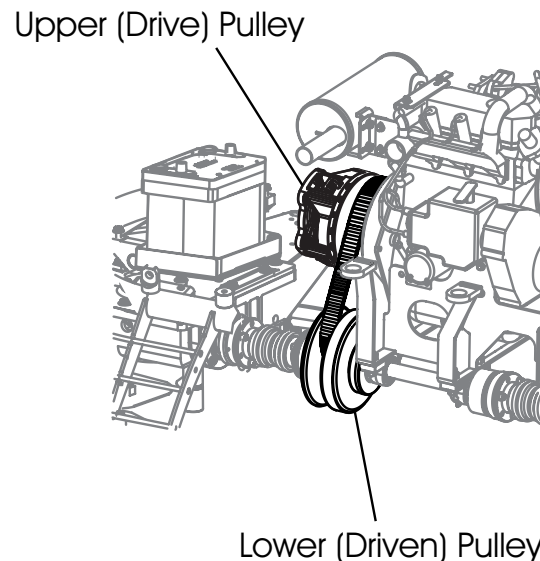

Figure 29. Drive Belt, Belt Holder and Pulleys

MAINTENANCE (NEW STYLE CLUTCH)

2. Disconnect the left-side CV Axle from the left-side gearbox and the lower drive pulley coupler. See Figure 30.

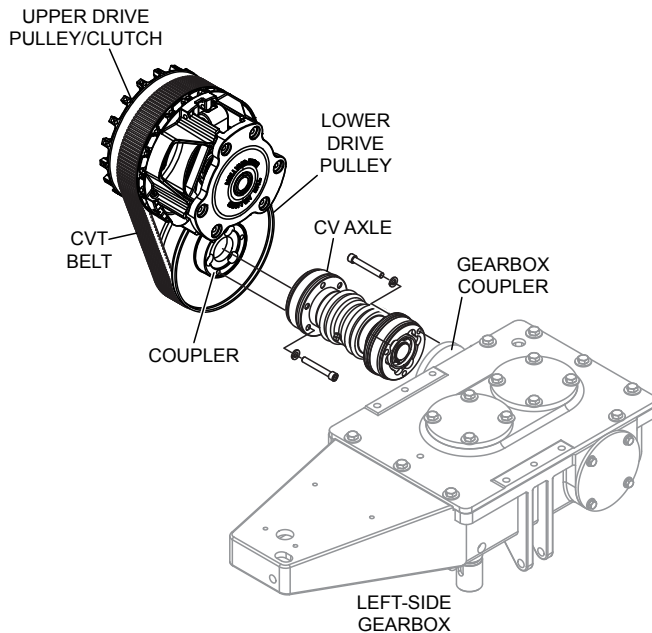

Figure 30. Remove Left-Side CV Axle

3. If the belt is not being reused (recommended), CUT the drive belt. Ensure all belt remnants are removed from the pulleys.

INSTALLING DRIVE BELT

1. Place new CVT belt over the lower pulley. Squeeze the belt (Figure 31) and pull the belt upwards and towards the rear of the trowel. This will spread open the faces of the lower drive pulley.

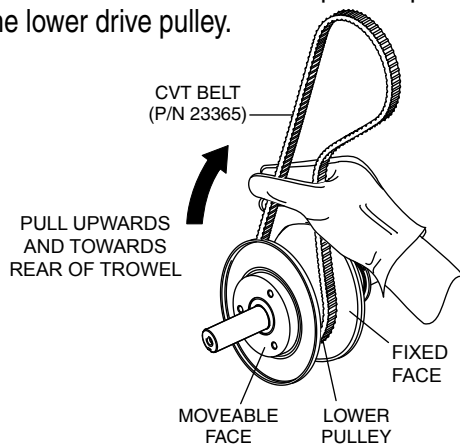

Figure 31. Holding Lower Pulley Open

2. Place free end of CVT belt into upper pulley grooves See Figure 32.

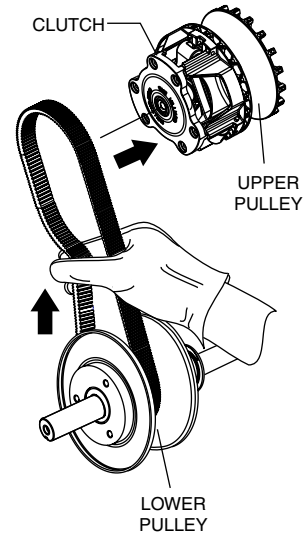

Figure 32. Upper Pulley Belt Installation

3. Reconnect left-side CV Axle Assembly to the left side gearbox and lower drive pulley coupler. See Figure 30.

MAINTENANCE (NEW STYLE CLUTCH)

HOW IT WORKS

The Multi-Clutch functions much like a standard CVT system. As the engine RPM's increase, the drive or primary clutch closes, forcing the belt to ride outwards on the drive sheaves. The closing of the drive clutch also forces the belt to open the driven or secondary sheaves. The opening and closing of these sheaves creates a ratio variation... hence CVT or Continuously Variable Transmission.

Belt protection is achieved within the Multi-Clutch through the use of a series of centrifugal clutches. While most CVT systems have a loose or slack belt while the engine idles, the sheaves of those systems are constantly rotating and wearing on the belt.

Those systems also require the stationary belt to be pinched by the constantly rotating sheaves during startup. The relative rotation of the sheaves to the belt causes unnecessary wear on the belt. With traditional CVT systems, wear on the belt happens any time the engine is idling and at every start up of the driven equipment. This is where the Multi-Clutch differs from the other CVT's.

The Multi-Clutch utilizes two centrifugal clutches (the starter clutch system) to drive the sheaves of the drive (primary) clutch. What that means is that the belt can remain tight in the sheaves, and that both the sheaves and the belt are stationary while the vehicle is idling. This eliminates the belt wear at an idle, and during start up, while also providing one additional form of belt protection.

The centrifugal clutches (starter clutch) can act as overload protection as well. In cases where too much torque is trying to be transmitted to the belt, the centrifugals can slip before the maximum load on the belt is achieved. What this means is that instead of the belt slipping on the sheaves during an overload, the centrifugals will first slip further protecting the belt from damage.

Blade Pitch

Matching Blade Pitch for Both Sets of Blades

Sometimes it may be necessary to match blade pitch between the two sets of blades. There are some signs that this may be necessary. For example, the differences in pitch could cause a noticeable difference in finish quality between the two sets of blades, or, the difference in blade pitch could make the machine difficult to control. This is due to the surface area in contact with the concrete (the blade set with the greater contact area tends to stick to the concrete more).

Single Pitch

On a Single Pitch trowel each spider assembly can be pitched individually, forcing the operator to constantly make adjustments on each pitch tower.

CAUTION

When turning an adjustment handle, do not force it to turn or damage to the cable may occur. If the cable starts to noticeably twist this is a good indication that one side is either all ready at full pitch or it is bound up due to concrete, debris, or corrosion.

Twin Pitch™

Trowels equipped with Twin Pitch™ Controls may need to have blade pitch between the two sets of blades "synchronized". If the blades need to be synchronized this is easily accomplished by performing the following. Refer to Figure 33.

1. Lift the pitch adjustment handle on either side. Once lifted, that side is now disconnected from the Twin Pitch system.
2. Adjust to match the opposite side.
3. When adjusted, lower the handle to Twin Pitch operating position.

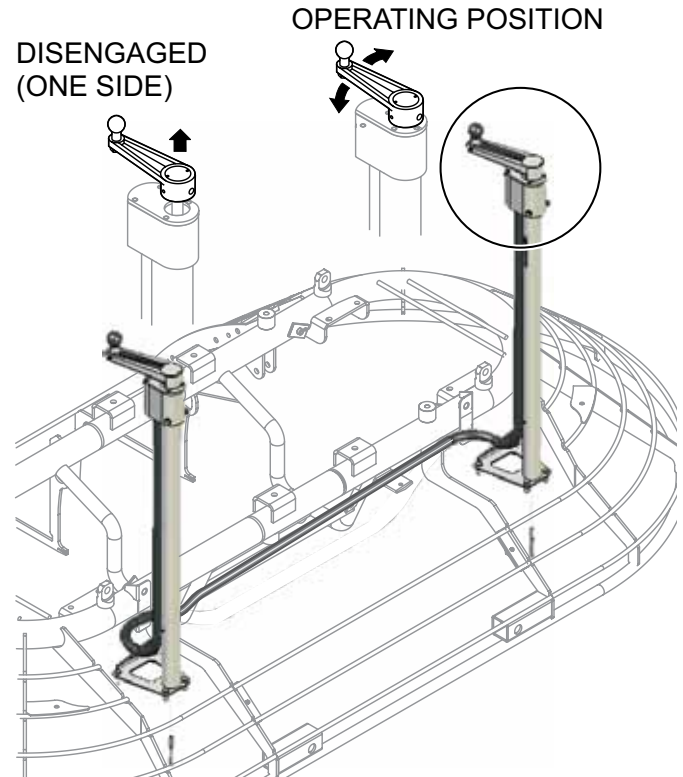

Figure 33. Pitch Towers

Blade Pitch Adjustment Procedure

Maintenance adjustment of blade pitch is made by adjusting a bolt (Figure 34) on the arm of the trowel blade finger. This bolt is the contact point of the trowel arm to the lower wear plate on the thrust collar. The goal of adjustment is to promote consistent blade pitch and finishing quality.

Look for the following indications if blades are wearing unevenly. If so, adjustment may be necessary.

- Is one blade is completely worn out while the others look new?
- Does the machine have a perceptible rolling or bouncing motion when in use?

- Look at the machine while it is running, do the guard rings “rock up and down” relative to the ground?
- Do the pitch control towers rock back and forth?

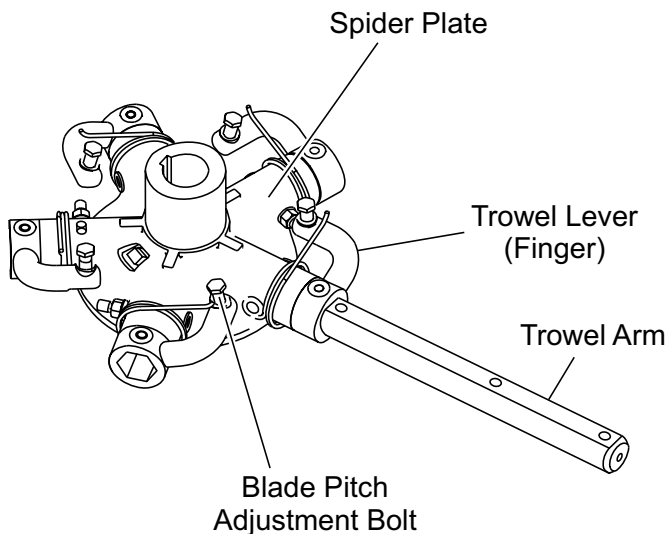

Figure 34. Blade Pitch Adjustment Bolt

The easiest and most consistent way to make adjustments on the trowel arm fingers is to use the Trowel Arm Adjustment Fixture (P/N 9177). It comes with all the hardware necessary to properly accomplish this maintenance and instructions on how to utilize this tool.

If a trowel arm adjustment fixture is not available and immediate adjustment is necessary, temporary field adjustment can be made if you can see or feel which blade is pulling harder by adjusting the bolt that corresponds to that blade.

A better way to determine which blades need adjustment is to place the machine on a known FLAT surface (steel metal plate) and pitch the blades as flat as possible. Look at the adjustment bolts. They should all barely make contact with the lower wear plate on the spider. If you can see that one of them is not making contact, some adjustment will be necessary.

Adjust the “high” bolts down to the level of the one that is not touching, or adjust the “low” bolt up to the level of the higher ones. If possible, adjust the low bolt up to the level of the rest of the bolts. This is the fastest way, but may not always work. Verify after adjustment the blades pitch correctly.

Blades that are incorrectly adjusted often will not be able to pitch flat. This can occur if the adjusting bolts are raised too

high. Conversely, adjusting bolts that are too low will not allow the blades to be pitched high enough for finishing operations.

If, after making Blade Pitch adjustments the machine is still finishing poorly, blades, trowel arms, and trowel arm bushings may be suspect and should be looked at for adjustment, wear, or damage. See the following sections.

Changing Blades

It is recommended that ALL the blades on the entire machine are changed at the same time. If only one or some of the blades are changed, the machine will not finish concrete consistently and the machine may wobble or bounce.

1. Place the machine on a flat, level surface. Adjust the blade pitch control to make the blades as flat as possible. Note the blade orientation on the trowel arm. This is important for ride-on trowels as the two sets of blades counter-rotate. Lift the machine up, placing blocks under the main guard ring to support it.
2. Remove the bolts and lock washers on the trowel arm, and then remove the blade.
3. Scrape all concrete and debris from the trowel arm. This is important to properly seat the new blade.
4. Install the new blade, maintaining the proper orientation for direction of rotation.
5. Reinstall the bolts and lock washers.
6. Repeat steps 2-5 for all remaining blades.

Steering Adjustment

The steering assist adjustment should be performed only by qualified service technicians. For HHXD5 steering adjustment instructions, reference MQ Whiteman service bulletin 200925.

Clean-Up

Never allow concrete to harden on the power trowel. Immediately after use wash any concrete off the trowel with water, be careful not to spray a hot engine or muffler. An old paint brush or broom may help loosen any concrete that has started to harden.

TROWEL ARM ADJUSTMENT

Use the following procedure to check and adjust trowel arms, and check for worn or damaged components when it becomes apparent that the trowel is finishing poorly or in need of routine maintenance.

Look for the following indications. Trowel arm alignment, worn spider bushings or bent trowel arms may be the cause.

- Are blades wearing unevenly? Is one blade completely worn out while the others look new?
- Does the machine have a perceptible rolling or bouncing motion when in use?
- Look at the machine while it is running; do the guard rings “rock up and down” relative to the ground?

1. Place the trowel in a FLAT, LEVEL area.

A level, clean area to test the trowel prior to and after is essential. Any unlevel spots in the floor or debris under the trowel blades will give an incorrect perception of adjustment. Ideally, a 5 x 5 Ft. (1.5 x 1.5 Meter) three-quarter inch (19 mm) thick FLAT steel plate should be used for testing.

2. Pitch the blades as flat as possible. The adjustment bolts should all barely make contact with the lower wear plate on the spider. If one is not making contact, adjustment will be necessary. (Figure 35).

Figure 35 illustrates, "incorrect alignment", worn spider bushings or bent trowel arms. Check that the adjustment bolt is barely touching (0.10" max. clearance) lower wear plate. All alignment bolts should be spaced the same distance from the lower wear plate.

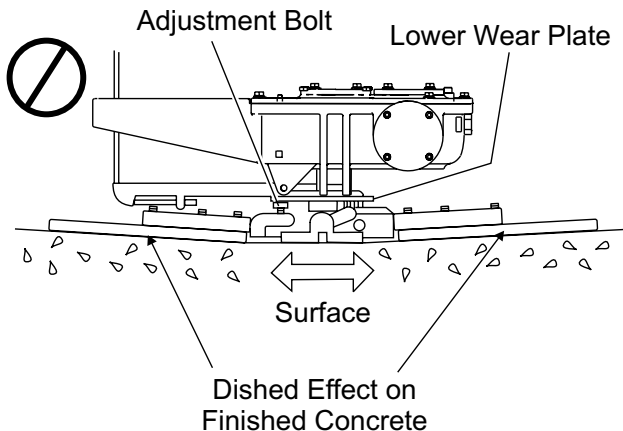

Figure 35. Incorrect Spider Plate Alignment

Figure 36 illustrates the "correct alignment" for a spider plate (as shipped from the factory).

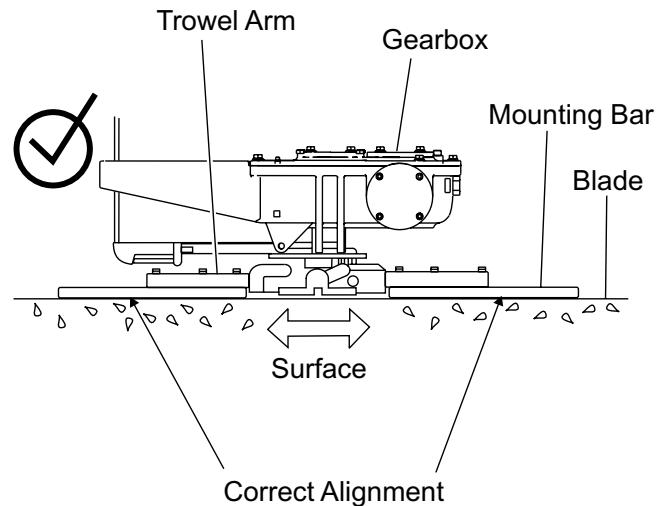

Figure 36. Correct Spider Plate Alignment

Spider Removal

Remove the spider assembly from the gearbox shaft as follows:

1. Locate the cone point square head set screw (Figure 37) and attached jam nut found on the side of the spider assembly.

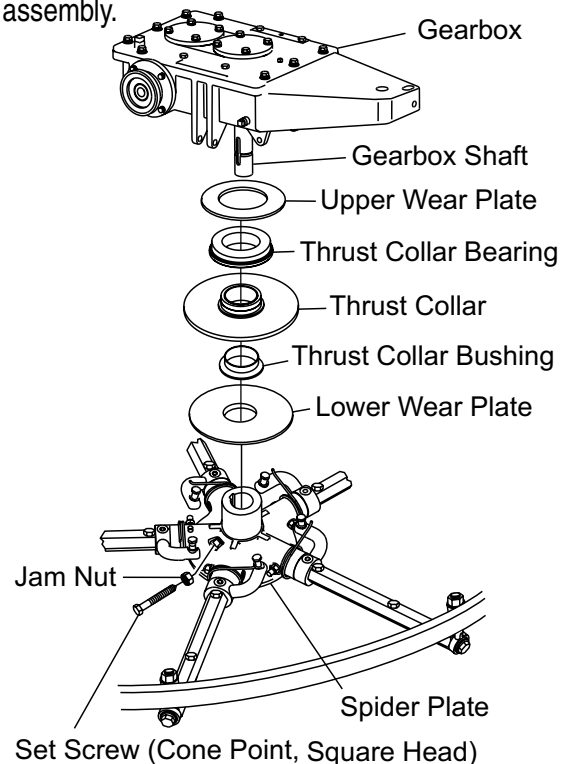

Figure 37. Spider/Gearbox Removal

2. Loosen the jam nut and cone point square head set screw.
3. Carefully lift the upper trowel assembly off of the spider assembly. A slight tap with a rubber mallet may be necessary to dislodge the spider from the main shaft of the gearbox.

Trowel Blade Removal

Remove the trowel blades by removing the three hex head bolts (Figure 38) from the trowel arm. Set blades aside.

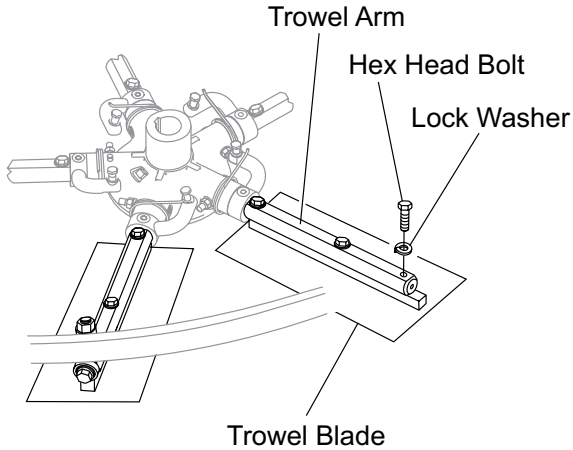

Figure 38. Trowel Blades

Trowel Arm Removal

1. Remove the hardware securing the stabilizer ring to the trowel arm (Figure 39).
2. Each trowel arm is held in place at the spider plate by a hex head bolt (zerk grease fitting) and a roll pin. Remove both the hex head bolt and the roll pin (Figure 40) from the spider plate.
3. Remove the trowel arm from the spider plate.

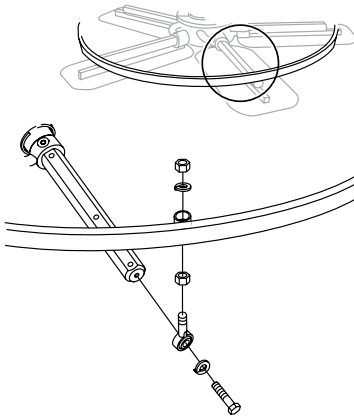

Figure 39. Stabilizer Ring

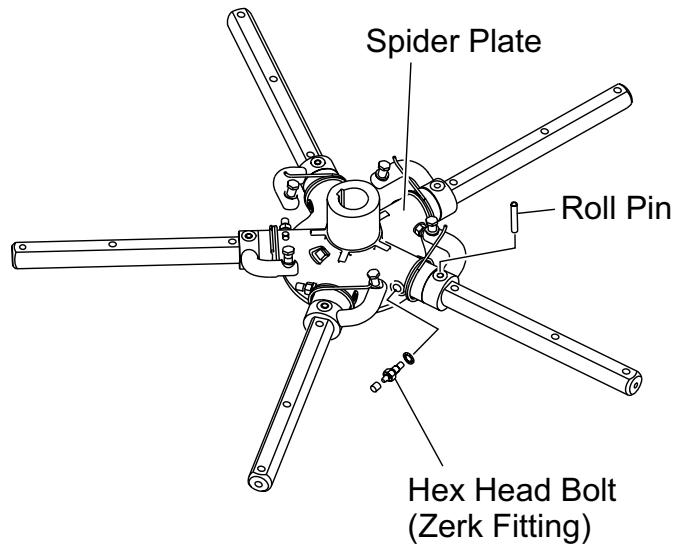

Figure 40. Removing Roll Pin and Grease Zerk Fitting

4. Should the trowel arm inserts (bronze bushing) come out with the trowel arm, remove the bushing from the trowel arm and set aside in a safe place. If the bushing is retained inside the spider plate, carefully remove the bushing.
5. Examine the bronze trowel arm bushing (Figure 41), and clean if necessary. Replace bushing if out-of-round or worn.

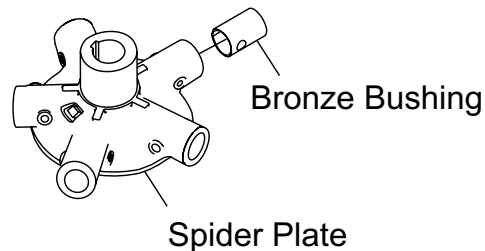

Figure 41. Bronze Bushings

6. Wire brush any build-up of concrete from all six sides of the trowel arm. Repeat this for the remaining arms.

Checking Trowel Arm Straightness

Trowel arms can be damaged by rough handling, (such as dropping the trowel on the pad), or by striking exposed plumbing, forms, or rebar while in operation. A bent trowel arm will not allow the trowel to operate in a smooth fluid rotation. If bent trowel arms are suspect, check for flatness as follows, refer to Figure 42 and Figure 43:

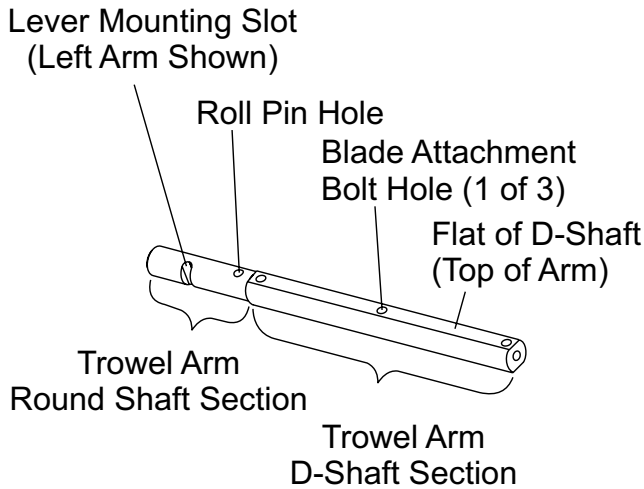

Figure 42. Trowel Arm

1. Use a thick steel plate, granite slab or any surface which is true and flat, to check all six sides of each trowel arm for flatness.
2. Check each of the six sides of the trowel arm (hex section). A feeler gauge of .004" (0.10 mm) should not pass between the flat of the trowel arm and the test surface along its length on the test surface. (Figure 43).

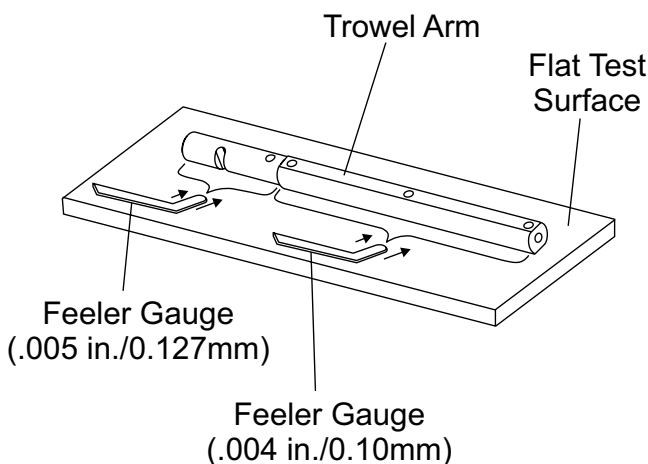

Figure 43. Checking Trowel Arm Flatness

3. Next, check the clearance between the round shaft and the test surface as one of the flat hex sections of the arm rests on the test surface. Rotate the arm to each of the flat hex sections and check the clearance of the round shaft. Use a feeler gauge of .005" (0.127 mm). Each section should have the same clearance between the round of the trowel arm shaft and the test surface.
4. If the trowel arm is found to be uneven or bent, replace the trowel arm.

Trowel Arm Adjustment

Shown in Figure 44 is the adjustment fixture with a trowel arm inserted. As each trowel arm is locked into the fixture, the arm bolt is adjusted to where it contacts a stop on the fixture. This will consistently adjust all of the trowel arms, keeping the finisher as flat and evenly pitched as possible.

1. Locate the trowel arm adjustment tool P/N 9177.

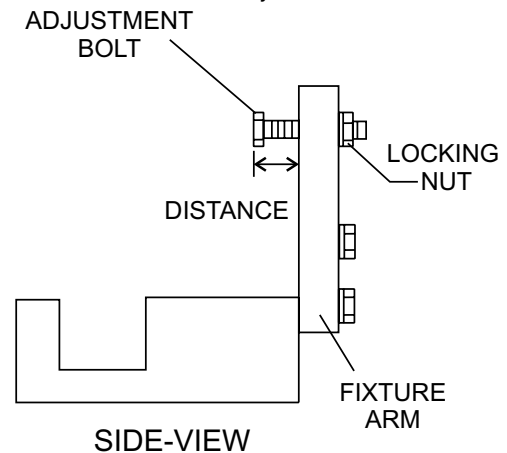

Figure 44. Trowel Arm Adjustment Tool Side View

2. Ensure the fixture arm is in the proper setting (up or down) for your trowel arm rotation as shown in Figure 45.

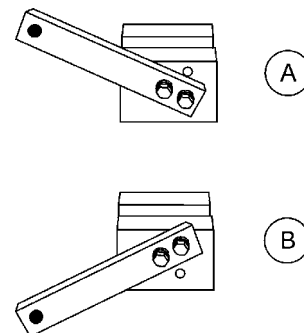

Figure 45. Trowel Arm Adjustment Setup

NOTICE

Arms with CLOCK-WISE blade rotation use the fixture arm in the UP position (A in Figure 45). Arms with COUNTER CLOCK-WISE blade rotation use the fixture with the fixture arm in the DOWN position. (B in Figure 45).

3. Unscrew the locking bolts on the adjustment tool and place the trowel arm into the fixture channel as shown in Figure 46. A thin shim may be required to cover the blade holes on the trowel arm. Make sure to align the trowel adjustment bolt with the fixture adjustment bolt.

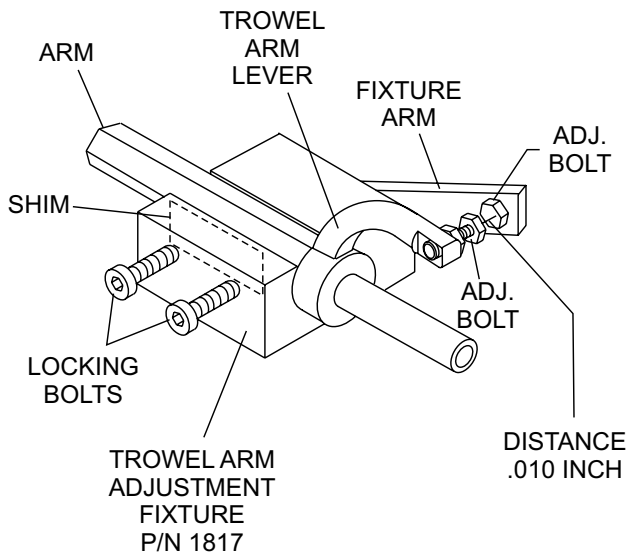

Figure 46. Trowel Arm Adjustment Fixture Components

4. Use an allen wrench to tighten the locking bolts securing the trowel arm in place.
5. Adjust the bolt "distance" shown in Figure 44 to match one of the arms. The other arms will be adjusted to match this distance.
6. Loosen the locking nut on the trowel arm lever, then turn the trowel arm adjusting bolt until it barely touches (.010") the fixture adjusting bolt.
7. Once the correct adjustment is made, tighten the lock nut on the trowel arm to lock in place.
8. Loosen locking nuts on the adjustment fixture, and remove trowel arm.
9. Repeat steps for the remaining trowel arms.

Re-Assembly

1. Clean and examine the upper/lower wear plates and thrust collar. Examine the entire spider assembly. Wire brush any concrete or rust build-up. If any of the spider components are found to be damaged or out of round, replace them.
2. Make sure that the bronze trowel arm bushing is not damage or out of round. Clean the bushing if necessary. If the bronze bushing is damaged or worn, replace it.
3. Reinstall bronze bushing onto trowel arm.
4. Repeat steps 2-3 for each trowel arm.
5. Make sure that the spring tensioner is in the correct position to exert tension on the trowel arm.
6. Insert all trowel arms with levers into spider plate (with bronze bushing already installed) using care to align grease hole on bronze bushing with grease hole fitting on spider plate.
7. Lock trowel arms in place by tightening the hex head bolt with zerk grease fitting and jam nut.
8. Re-install the blades onto the trowel arms.
9. Install stabilizer ring onto spider assembly.
10. Lubricate all grease points (zerk fittings) with premium "Lithum 12" based grease, conforming to NLG1 Grade #2 consistency.

Installing Pans Onto Finisher Blades

These round discs sometimes referred to as "pans" attach to the spiders arms and allow early floating on wet concrete and easy movement from wet to dry areas. They are also very effective in embedding large aggregates and surface hardeners.

WARNING



Lifting/Crush Hazard. **DO NOT** lift trowel with pans attached.

WARNING

ALWAYS install pans either on the work area or on an area that is next to and level with the work area. **DO NOT** lift the trowel when the pans are attached.

Refer to Figure 47 when installing pans onto finisher blades.

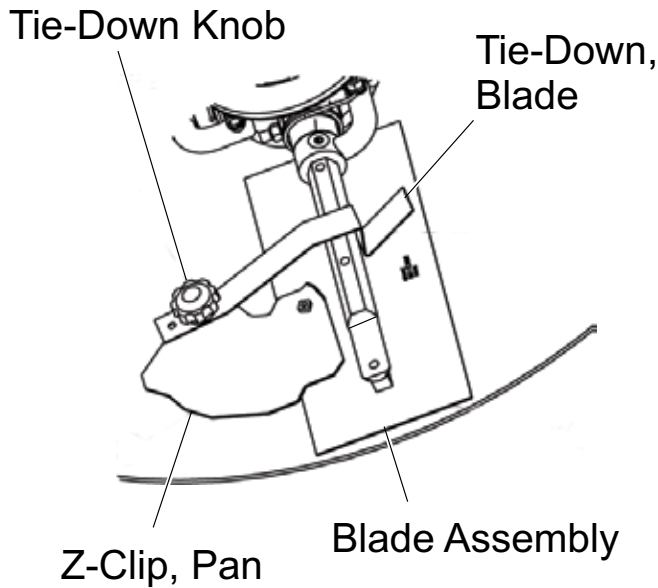

Figure 47. Z-Clip Finisher Pan Installation

1. Lift trowel just enough to slide pan under blades. Lower finisher onto pan with blades assembly adjacent to Z-Clips.
2. Rotate blades into position under Z-Clips. Ensure that the blades are rotated in the direction of travel when the machine is in operation or use the engine to rotate the blades into position.
3. Attach the blade tie-downs to the far side of the Z-Clip brackets with tie-down knobs as shown in figure 42.
4. Check to make certain that the blade edges are secured under the Z-Clips and the tie-downs are secured completely over the edges of the blade bar before the machine is put back into operation.

Hydraulic Steering Pressure

WARNING

NEVER use your hand to find hydraulic leaks. Use a piece of wood or cardboard. Hydraulic fluid injected into the skin must be treated by a knowledgeable physician immediately or severe injury or death can occur.

Many hydraulic problems are a result of low fluid levels. Before checking any other possibilities, make sure the hydraulic fluid is at the proper level in the hydraulic fluid tank.

Checking Steering Pressure

CAUTION

This procedure will require two or more people. The trowel will need to be "run up" while remaining stationary or otherwise held in position. If a "hover" is difficult to maintain the trowel can be butted up to 2 or 3 stakes or to some other none-moveable items.

1. Remove the Left Side Access Cover and insert the test pressure gauge (300 to 600 PSI) as shown in Figure 48 into the left steering valve's diagnostic quick coupler.
2. Verify the hydraulic fluid level is correct.
3. Start the engine and allow the unit to warm up.
4. Move the throttle lever to FULL engine RPM.
5. View the gauge and record the reading.

Interpreting the Pressure Reading

WARNING

Charge/Steering Pressure must NEVER exceed 300 PSI nor go below 150 PSI. Pressure too high may result in pressure leaks while pressure too low may result in system damage.

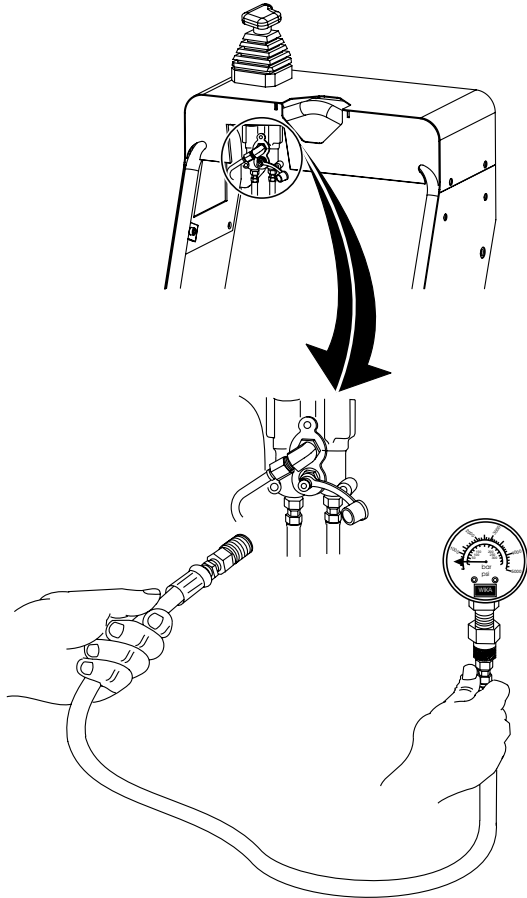

Figure 48. Steering Pressure Check

The left steering valve's factory setting is 230 PSI, however some operators may prefer a more responsive steering (higher pressure required; 300 PSI maximum) and some operators may prefer a "softer feel" (lower pressure required; not less than 150 PSI).

Steering Pressure Adjustment

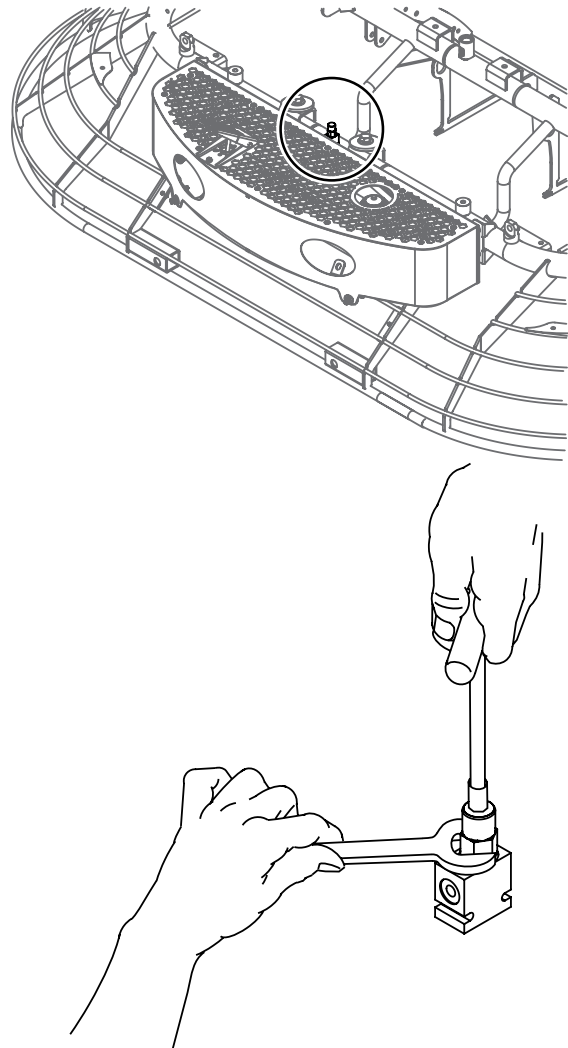

Figure 49. Steering Pressure Adjustment

Remember, the trowel will need to be kept stationary during "run-up" while checking the pressure.

1. Remove front grille guard.
2. Loosen jam nut on pilot relief valve (Figure 49).
3. Use allen wrench to adjust the steering pressure to the desired setting. (between 150 and 300 PSI) See **Checking Steering Pressure** procedures.
4. Retighten jam nut.
5. Remove pressure gauge and reinstall access grilles.

DECOMMISSIONING TROWEL

Decommissioning is a controlled process used to safely retire a piece of equipment that is no longer serviceable. If the equipment poses an unacceptable and unreparable safety risk due to wear or damage or is no longer cost effective to maintain, (beyond life-cycle reliability) and is to be decommissioned, (demolition and dismantlement), the following procedure must take place:

1. Drain all fluids completely. These may include oil, Diesel, hydraulic oil and antifreeze. Dispose of properly in accordance with local and governmental regulations. Never pour on ground or dump down drains or sewers.
2. Remove battery and bring to appropriate facility for lead reclamation. Use safety precautions when handling batteries that contain sulfuric acid, (See page 11).
3. The remainder can be brought to a salvage yard or metal reclamation facility for further dismantling.

FUEL SYSTEM DIAGRAM

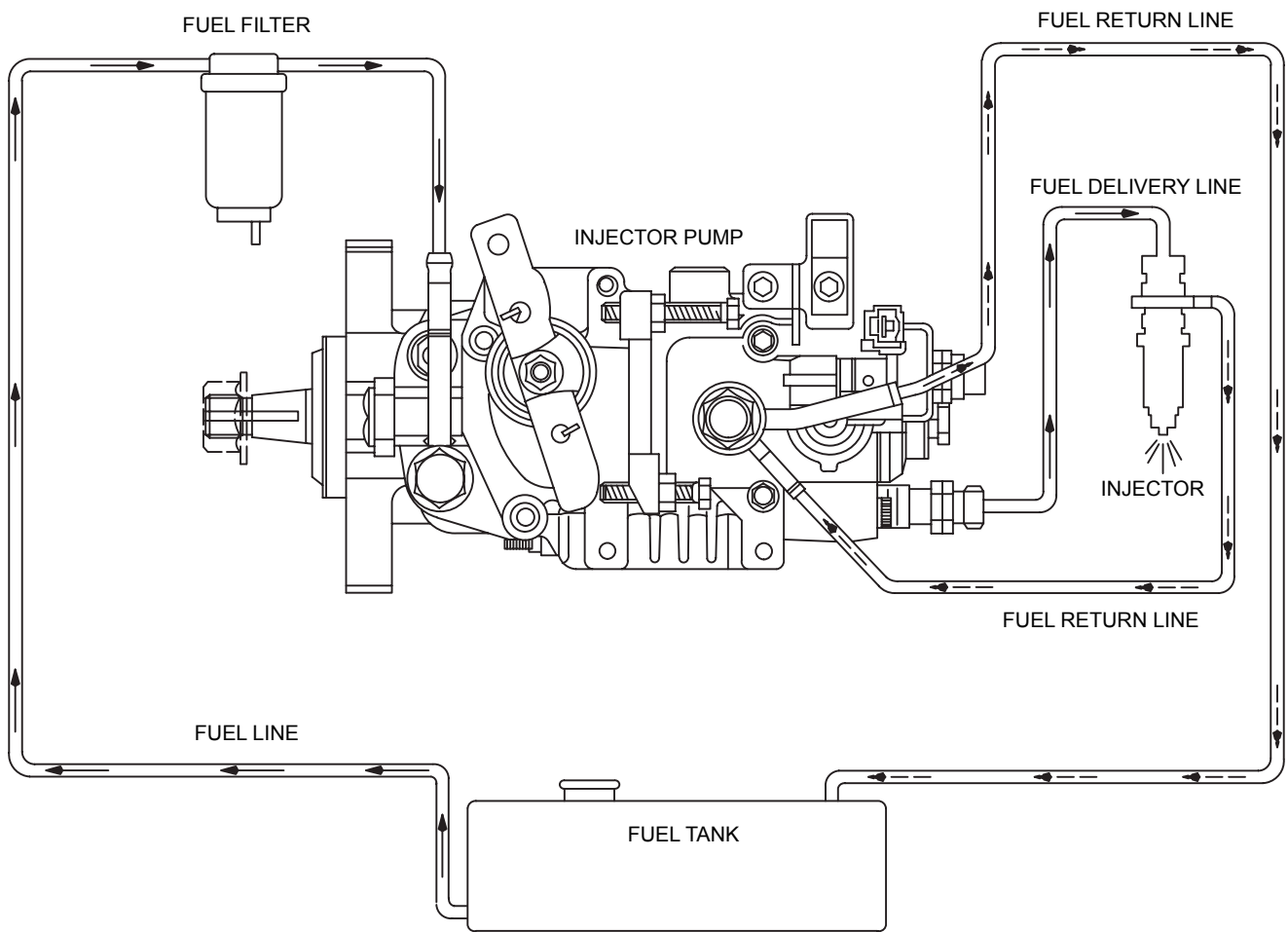

WIRING DIAGRAM (ENGINE)

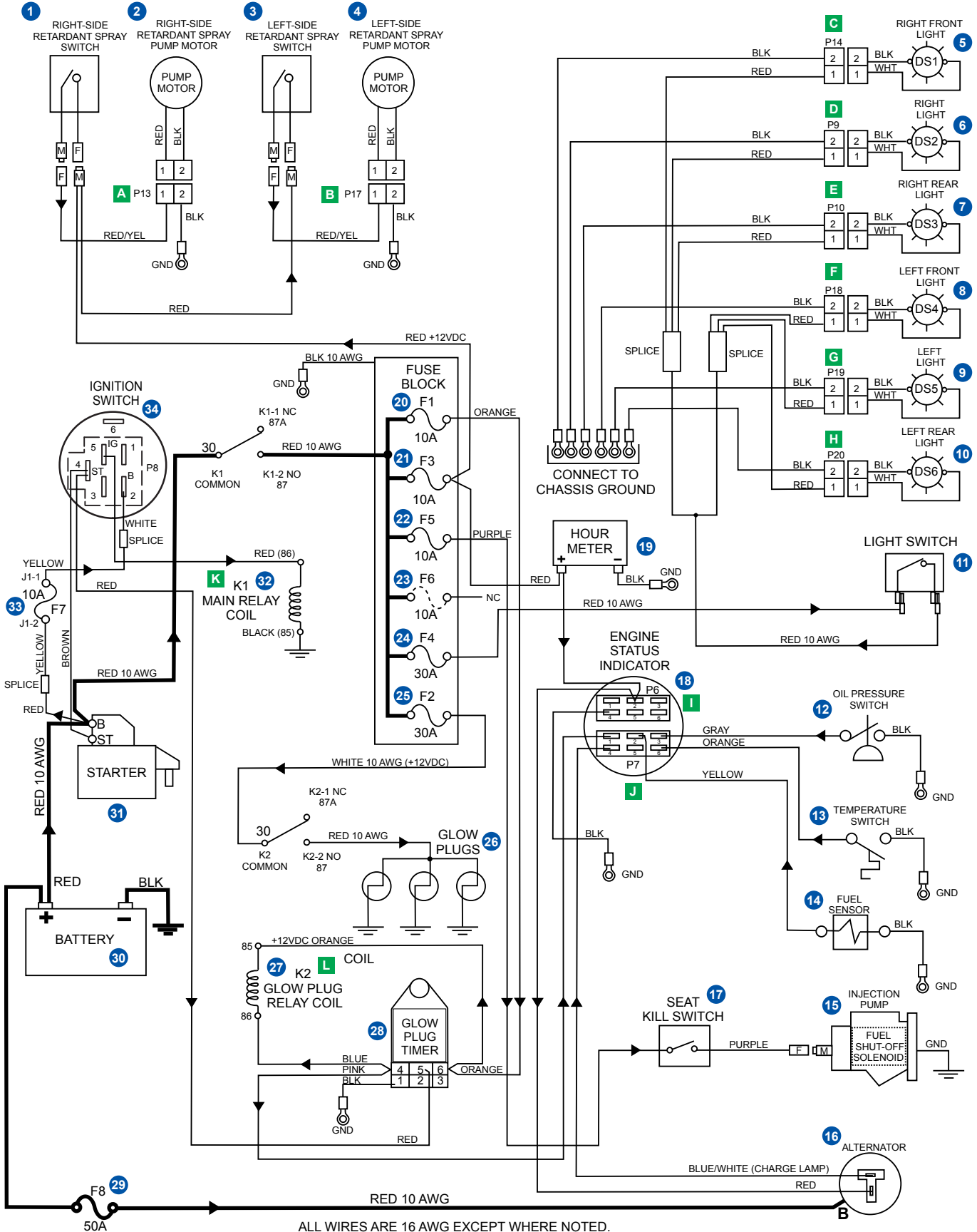

WIRING DIAGRAM (ENGINE)

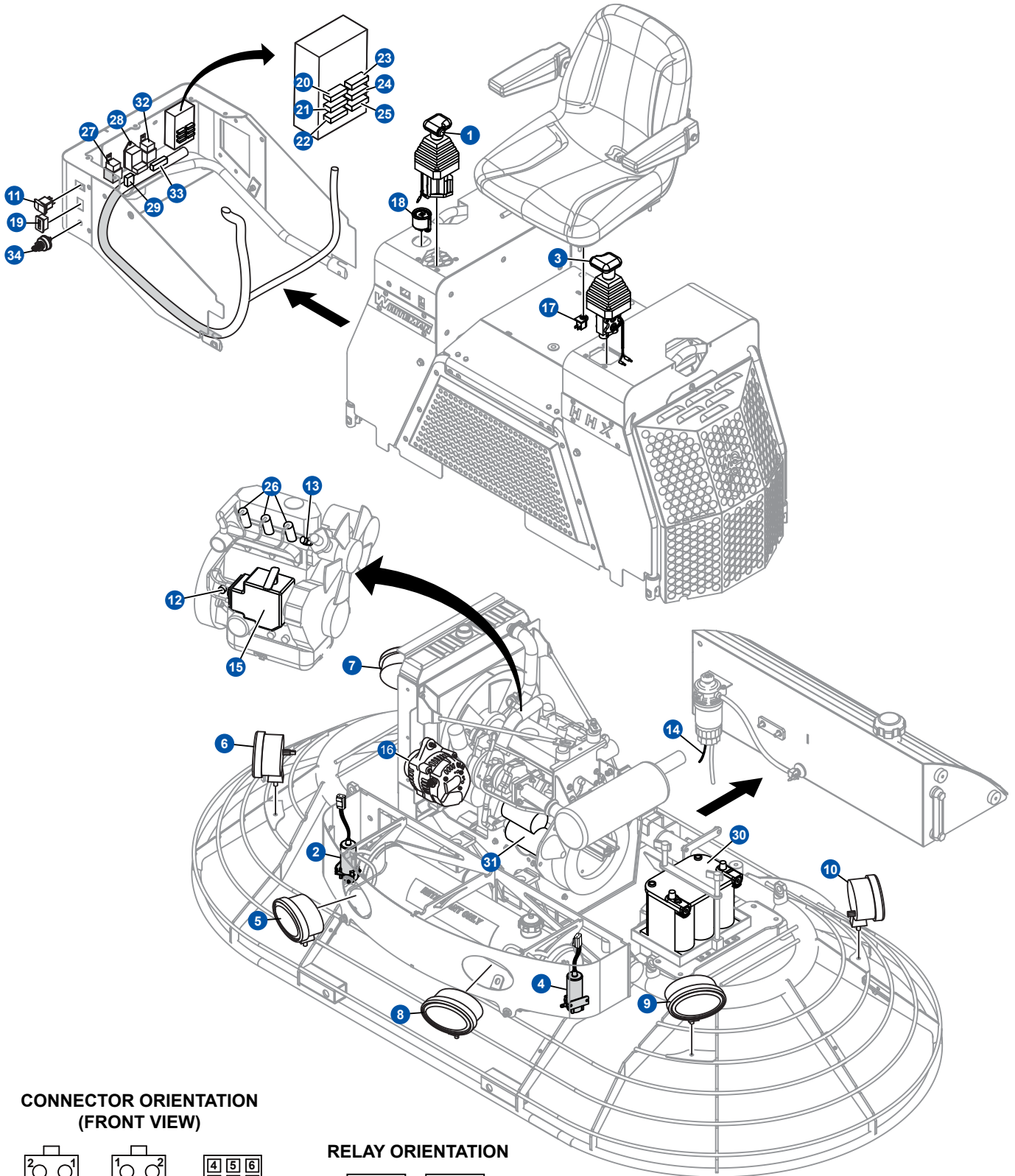

CONNECTOR ORIENTATION (FRONT VIEW)

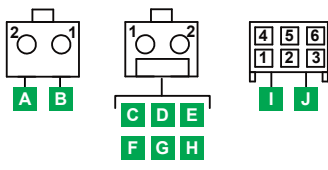

RELAY ORIENTATION

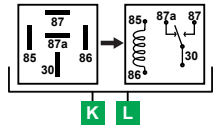

TROUBLESHOOTING

Troubleshooting (Ride-On Trowel)		
Symptom	Possible Problem	Solution
Engine running rough or not at all.	Stop switch malfunction?	Make sure that the stop switch is functioning when the operator is seated. Replace switch if necessary.
	Fuel?	Look at the fuel system. Make sure there is fuel being supplied to the engine. Check to ensure that the fuel filter is not clogged.
	Ignition?	Check to ensure that the ignition switch has power and is functioning correctly.
Safety stop switch not functioning.	Bad contacts?	Replace switch.
	Loose wire connections?	Check wiring. Replace as necessary.
	Other problems?	Consult engine manufacturer's manual.
Trowel bounces, rolls concrete, or makes uneven swirls in concrete.	Blades?	Make sure blades are in good condition, not excessively worn. Finish blades should measure no less than 2 inches (50mm) from the blade bar to the trailing edge, combo blades should measure no less than 3.5 inches (89mm). Trailing edge of blade should be straight and parallel to the blade bar.
	Pitch Adjustment?	Check that all blades are set at the same pitch angle as measured at the spider. A field adjustment tool is available for height adjustment of the trowel arms (contact Parts Department).
	Bent trowel arms?	Check the spider assembly for bent trowel arms. If one of the arms is even slightly bent, replace it immediately.
	Trowel arm bushings?	Check the trowel arm bushings for tightness. This can be done by moving the trowel arms up and down. If there is more than 1/8 inch (3.2 mm) of travel at the tip of the arm, the bushings should be replaced. All bushings should be replaced at the same time.
	Thrust collar?	Check the flatness of the thrust collar by rotating it on the spider. If it varies by more than 0.02 inch (0.5 mm) replace the thrust collar.
	Thrust collar bushing?	Check the thrust collar by rocking it on the spider. If it can tilt more than 1/16 inch (1.6 mm) - as measured at the thrust collar O.D., replace the bushing in the thrust collar.
	Thrust bearing worn?	Check the thrust bearing to see that it is spinning freely. Replace if necessary.
Machine has a perceptible rolling motion while running.	Main shaft?	The main output shaft of the gearbox assembly should be checked for straightness. The main shaft must run straight and cannot be more than 0.003 inch (0.08 mm) out of round at the spider attachment point.
	Yoke?	Check to make sure that both fingers of the yoke press evenly on the wear cap. Replace yoke as necessary.
	Blade Pitch?	Check to ensure that each blade is adjusted to have the same pitch as all other blades. Adjust per maintenance section in manual.

TROUBLESHOOTING

Troubleshooting (Ride-On Trowel) - continued		
Symptom	Possible Problem	Solution
Lights (optional) not working.	Wiring?	Check all electrical connections in the lighting circuit. Verify wiring is in good condition with no shorts. Replace defective wiring or components immediately.
	Lights?	If +12VDC is present at light fixture connector when light switch is activated and light does not turn on, replace light bulb.
	Bad switch?	Check the continuity of light switch. Replace light switch if defective.
	Bad fuse?	Check fuse. Replace fuse if defective.
Retardant spray (optional) not working.	Retardant?	Check retardant level in tank. Fill tank as required.
	Wiring?	Check all electrical connections in the spray pump circuit. Verify wiring is in good condition with no shorts. Replace defective wiring or components immediately.
	Bad switch?	Check the continuity of both left and right spray switches (palm handles). Replace spray switch if defective..
	Bad spray pump?	If +12VDC is present at pump connector when spray switch is activated and pump does not operate, replace spray pump.
	Bad fuse?	Check fuse. Replace fuse if defective.
Steering is unresponsive.	Blade speed out of adjustment?	See section on blade speed adjustment.
	Pivots?	Check to ensure free movement of hydraulic drive motors.
	Hydraulic pressure?	Check to ensure that hydraulic pressure is adequate. See section on checking hydraulic pressure.
Operating position is uncomfortable.	Seat adjusted for operator?	Adjust seat with lever located on the front of the seat.
Linkage on Twin Pitch Tower not working.	Broken pitch tower components?	Inspect all pitch tower components. Replace all defective components immediately.
	Defective drive pitch cable?	Inspect drive pitch cable. Replace if defective or broken.
Clutch slipping or sluggish response to engine speed change.	Worn belts?	Replace belt.
	Clutch out of adjustment?	Adjust per instructions in maintenance section of this manual.
	Worn or defective clutch parts?	Replace parts as necessary.
	Worn bearings in gearbox?	Rotate input shaft by hand. If shaft rotates with difficulty, check the input and output shaft bearings. Replace as necessary.
	Worn or broken gears in gearbox?	Verify that the gearbox shaft rotates when the input shaft is rotated. Replace both the worm and worm gear as a set.

TROUBLESHOOTING

Troubleshooting (Engine)		
Symptom	Possible Problem	Solution
Engine will not start or start is delayed, although engine can be turned over.	No Fuel reaching injection pump?	Add fuel. Check entire fuel system.
	Defective fuel pump?	Replace fuel pump.
	Fuel filter clogged?	Replace fuel filter and clean tank.
	Faulty fuel supply line?	Replace or repair fuel line.
	Compression too low?	Check piston, cylinder and valves. Adjust or repair per engine repair manual.
	Fuel pump not working correctly?	Repair or replace fuel pump.
	Oil pressure too low?	Check engine oil pressure.
	Low starting temperature limit exceeded?	Comply with cold starting instructions and proper oil viscosity.
	Defective battery?	Charge or replace battery.
	Air or water mixed in fuel system?	Check carefully for loosened fuel line coupling, loose cap nut, etc.
At low temperatures engine will not start.	Engine oil too thick?	Refill engine crankcase with correct type of oil for winter environment.
	Defective battery?	Replace battery.
Engine fires but stops soon as starter is switched off.	Fuel filter blocked?	Replace fuel filter.
	Fuel supply blocked?	Check the entire fuel system.
	Defective fuel pump?	Replace fuel pump.
Engine stops by itself during normal operation.	Fuel tank empty?	Add fuel.
	Fuel filter blocked?	Replace fuel filter.
	Defective fuel pump?	Replace fuel pump.
	Mechanical oil pressure shutdown sensor stops the engine due to low oil?	Add oil. Replace low oil shutdown sensor if necessary.
Low engine power, output and speed.	Fuel tank empty?	Replace fuel filter.
	Fuel filter clogged?	Replace fuel filter.
	Fuel tank venting is inadequate?	Ensure that tank is adequately vented.
	Leaks at pipe unions?	Check threaded pipe unions tape and tighten unions as required.
	Speed control lever does not remain in selected position?	See engine manual for corrective action.
	Engine oil level too full?	Correct engine oil level.
	Injection pump wear?	Use No. 2-D diesel fuel only. Check the fuel injection pump element and delivery valve assembly and replace as necessary.

TROUBLESHOOTING

Troubleshooting (Engine) - continued		
Symptom	Possible Problem	Solution
Low engine power output and low speed, black exhaust smoke.	Air filter blocked?	Clean or replace air filter.
	Incorrect valve clearances?	Adjust valves per engine specification.
	Malfunction at injector?	See engine manual.
Engine overheats.	Too much oil in engine crankcase?	Drain off engine oil down to uppermark on dipstick.
	Entire cooling air system contaminated/ blocked?	Clean cooling air system and cooling fin areas.
	Fan belt broken or elongated?	Change belt or adjust belt tension.
	Coolant insufficient?	Replenish coolant.
	Radiator net or radiator fin clogged with dust?	Clean net or fin carefully.
	Fan, radiator, or radiator cap defective?	Replace defective part.
	Thermostat defective?	Check thermostat and replace if necessary.
Head gasket defective or water leakage?	Replace parts.	

OPERATION MANUAL

HERE'S HOW TO GET HELP

PLEASE HAVE THE MODEL AND SERIAL
NUMBER ON-HAND WHEN CALLING

UNITED STATES

Multiquip Corporate Office

18910 Wilmington Ave.
Carson, CA 90746
Contact: mq@multiquip.com

Tel. (800) 421-1244
Fax (800) 537-3927

Service Department

800-421-1244
310-537-3700

Fax: 310-537-4259

Technical Assistance

800-478-1244

Fax: 310-943-2238

MQ Parts Department

800-427-1244
310-537-3700

Fax: 800-672-7877
Fax: 310-637-3284

Warranty Department

800-421-1244
310-537-3700

Fax: 310-943-2249

MEXICO

MQ Cipsa

Carr. Fed. Mexico-Puebla KM 126.5
Momoxpan, Cholula, Puebla 72760 Mexico
Contact: pmastretta@cipsa.com.mx

Tel: (52) 222-225-9900
Fax: (52) 222-285-0420

CANADA

Multiquip

4110 Industriel Boul.
Laval, Quebec, Canada H7L 6V3
Contact: jmartin@multiquip.com

Tel: (450) 625-2244
Tel: (877) 963-4411
Fax: (450) 625-8664

UNITED KINGDOM

Multiquip (UK) Limited Head Office

Unit 2, Northpoint Industrial Estate,
Globe Lane,
Dukinfield, Cheshire SK16 4UJ
Contact: sales@multiquip.co.uk

Tel: 0161 339 2223
Fax: 0161 339 3226

© COPYRIGHT 2012, MULTIQUIP INC.

Multiquip Inc, the MQ logo and the Whiteman logo are registered trademarks of Multiquip Inc. and may not be used, reproduced, or altered without written permission. All other trademarks are the property of their respective owners and used with permission.

This manual MUST accompany the equipment at all times. This manual is considered a permanent part of the equipment and should remain with the unit if resold.

The information and specifications included in this publication were in effect at the time of approval for printing. Illustrations, descriptions, references and technical data contained in this manual are for guidance only and may not be considered as binding. Multiquip Inc. reserves the right to discontinue or change specifications, design or the information published in this publication at any time without notice and without incurring any obligations.

Your Local Dealer is:



PN: 23323